

**COUNTY OF SUTTER**  
**NEGATIVE DECLARATION**

**PROJECT TITLE:** Project #U24-0021 (Saini)

**PROJECT SPONSORS:** Applicant:  
Manjit Singh Saini  
4934 Kokomo Drive, Sacramento, CA 95835

Owner:  
Sri Guru Nanak Dev Sewa Society International  
Manjit Singh Saini, CEO  
4934 Kokomo Drive, Sacramento, CA 95835

Project Engineer/Surveyor:  
Harsev Singh  
Continental Development Consultants, Inc.  
P.O. Box 1924, Woodland, CA 95776

**PROJECT LOCATION:** 219 West Catlett Road, Nicolaus, CA 95659; on the south side of West Catlett Road, on the west side of Vernon Road, approximately 0.8 miles east of Garden Highway and the Feather River

**ASSESSOR'S PARCEL NO:** 34-090-019, 34-090-022, 34-090-023

**PROJECT DESCRIPTION:** An Administrative Permit to allow a small outdoor special events facility accommodating a maximum of 99 guests per event within the Agriculture (AG) Zoning District for events such as group picnics, birthdays, and weddings. An approximate one-acre outdoor area on the north side of the property is proposed for events. Events are limited to 12 per year with one event each month. Events will occur during daylight hours only with maximum hours between 7:00am and 6:00pm.

---

An Initial Study has been conducted by the Environmental Control Officer of the County of Sutter. The Environmental Control Officer finds that this project will not have a significant effect on the environment. The Initial Study is available for public review at the Sutter County Development Services Department, 1130 Civic Center Boulevard, Suite A, Yuba City, California. (Phone: 530-822-7400)

**STATEMENT OF REASONS TO SUPPORT FINDING  
OF NEGATIVE DECLARATION**

Staff has conducted an Initial Study for this project, which revealed that the proposed project will not have a significant impact on the environment.

  
\_\_\_\_\_  
Neal Hay  
Director of Development Services  
Environmental Control Officer

3-24-2025  
\_\_\_\_\_  
Date

## Sutter County Initial Study

- 1. Project title:** Project #U24-0021 (Saini)
- 2. Lead agency name and address:** Sutter County Development Services Department  
Planning Division  
1130 Civic Center Boulevard, Suite A  
Yuba City, CA 95993
- 3. Contact person and phone number:** Casey Murray, Senior Planner  
530-822-7400 ext. 245
- 4. Project sponsor's name and address:** Applicant:  
Manjit Singh Saini  
4934 Kokomo Drive  
Sacramento, CA 95835
- Owner:  
Sri Guru Nanak Dev Sewa Society International  
Manjit Singh Saini, CEO  
4934 Kokomo Drive  
Sacramento, CA 95835
- Engineer/Surveyor:  
Harsev Singh  
Continental Development Consultants, Inc.  
P.O. Box 1924  
Woodland, CA 95776
- 5. Project Location & APN:** 219 West Catlett Road, Nicolaus, CA 95659; on the south side of West Catlett Road, on the west side of Vernon Road, approximately 0.8 miles east of Garden Highway and the Feather River, approximately four miles west of State Highway 99, within the unincorporated area of Sutter County; APN: 34-090-019, 34-090-022, 34-090-023
- 6. General Plan Designation:** AG-40 (Agriculture, 40-acre minimum)
- 7. Zoning Classification:** AG (Agriculture) District
- 8. Description of project:** The proposed project is a request for an Administrative Permit to allow a small outdoor special events facility accommodating a maximum of 99 guests per event within the Agriculture (AG) Zoning District. A copy of the project plans is included as an attachment (see attachment 1).

The overall site consists of 60 acres on three separate 20-acre parcels. An approximate one-acre area on the north side of the property is proposed for events such as group picnics, birthdays, and weddings. Events will be limited to 12 per year with one event each month. Events will occur during daylight hours only with maximum hours between 7am and 6pm. No exterior lighting is needed or proposed.

The site will be directly accessed from West Catlett Road through an existing entrance through a 22-foot-wide access gate. The driveway connection to West Catlett Road will be required to be paved within the County right-of-way, which will require approval of an encroachment permit from the County. Besides uncultivated farmland with irrigation wells, the site contains one barn consisting of a prefabricated metal building (2,000 square feet), one unused horse-riding area (approximately 40,000 square feet), and one

storage container (8-foot by 10-foot). Special events are proposed to take place within the unused horse-riding area, which is enclosed by a four-foot-tall steel tubing fence.

Events are proposed to take place either on the third or fourth Sunday of each month. Set-up will take place one day before (Saturday) and taken down on the next day (Monday). Food is to be catered and bottled water will be served during events. Events will take place outdoors with rental tents/canopies. Two portable restroom trailers will be provided by the event organizers with each trailer having two toilets and one hand washing station. Restrooms will be self-contained and will be required to be serviced by a Sutter County registered septic pumper. The applicant anticipates a maximum of 50 vehicles for each event to be parked on a gravel surfaced portion of the existing horse arena. Five volunteers are proposed to work at the site for general upkeep and will direct traffic during events. A minimum of five trash receptacles will be put in place during events with trash to be hauled to the landfill by volunteers. Dust from car traffic will be contained by sprinkling water with tankers prior to the event day as well as regulating onsite speed to a maximum of five miles per hour. Two speed limit signs will be posted at the site entrance. An approximate 3,500 square foot temporary storage area near the front of the site is proposed for event accessories, when not in use, such as trash receptacles, portable restrooms, as well as for staging of tents/canopies materials that are hauled in one day before the event and hauled out one day after an event.

All events will be held in context of religious rituals of Sikh faith. Standard speakers and microphones will be used for chanting and singing of hymns from Sikh scriptures, such that event sound remains within property lines. The existing barn is not to be used for event activities. Signs will be posted at the front and side of the existing barn stating, "do not enter – private property."

As shown on the plans, 48 gravel surfaced parking spaces and two paved accessible spaces are proposed within the event area to accommodate event guests and volunteers. A non-illuminated single face free standing monument sign is proposed to be located near the site entrance as shown on the plans, which is consistent with Sutter County Zoning Code requirements.

The subject property currently drains to the northeast. A small drainage ditch is located on the east side of the property along Vernon Road. No new paving (other than two accessible parking spaces and driveway entrance) or buildings are proposed for this project, hence existing drainage will not be affected. Gravel is to be spread in the horse arena to contain dust.

**9. Surrounding land uses and setting:** The project is located at 219 West Catlett Road on a site totaling 60-acres. The site is on the south side of West Catlett Road, on the west side of Vernon Road, approximately 0.8 miles east of Garden Highway and the Feather River (see attachment 2). The project site and surrounding parcels are zoned AG (Agriculture) and are designated as AG-40 (Agriculture, 40-acre minimum) and AG-80 (Agriculture, 80-acre minimum) in the General Plan. The site is located within a rural area. Surrounding uses consist of agricultural crops which include rice, pistachio, walnuts, wheat, and triticale.

North: triticale; South: pistachio; East: wheat; West: walnut.

**10. Other public agencies whose approval is required:** None

**11. Have California Native American tribes traditionally and culturally affiliated with the project area requested consultation pursuant to Public Resources Code section 21080.3.1? If so, is there a plan for consultation that includes, for example, the determination of significance of impacts to tribal cultural resources, procedures regarding confidentiality, etc.?** The County initiated Assembly Bill 52 (AB 52) consultation through distribution of letters to the Native American tribes provided by the Native American Heritage Commission (NAHC). No request for consultation were received from Native American tribes during the review period.

**ENVIRONMENTAL FACTORS POTENTIALLY AFFECTED:**

The environmental factors checked below would be potentially affected by this project, involving at least one impact that is a “Potentially Significant Impact” as indicated by the checklist on the following pages.

- |  |   |   |
|--|---|---|
| <input type="checkbox"/> Aesthetics                    | <input type="checkbox"/> Agriculture and Forestry Resources | <input type="checkbox"/> Air Quality                        |
| <input type="checkbox"/> Biological Resources          | <input type="checkbox"/> Cultural Resources                 | <input type="checkbox"/> Energy                             |
| <input type="checkbox"/> Geology and Soils             | <input type="checkbox"/> Greenhouse Gas Emissions           | <input type="checkbox"/> Hazards and Hazardous Materials    |
| <input type="checkbox"/> Hydrology and Water Quality   | <input type="checkbox"/> Land Use and Planning              | <input type="checkbox"/> Mineral Resources                  |
| <input type="checkbox"/> Noise                         | <input type="checkbox"/> Population and Housing             | <input type="checkbox"/> Public Services                    |
| <input type="checkbox"/> Recreation                    | <input type="checkbox"/> Transportation                     | <input type="checkbox"/> Tribal Cultural Resources          |
| <input type="checkbox"/> Utilities and Service Systems | <input type="checkbox"/> Wildfire                           | <input type="checkbox"/> Mandatory Findings of Significance |

**DETERMINATION**

On the basis of this initial evaluation:

- I find that the proposed project **COULD NOT** have a significant effect on the environment, and a **NEGATIVE DECLARATION** will be prepared.
- I find that although the proposed project could have a significant effect on the environment, there will not be a significant effect in this case because revisions in the project have been made by or agreed to by the project proponent. A **MITIGATED NEGATIVE DECLARATION** will be prepared.
- I find that the proposed project **MAY** have a significant effect on the environment, and an **ENVIRONMENTAL IMPACT REPORT** is required.
- I find that the proposed project **MAY** have a “potentially significant impact” or “potentially significant unless mitigated” impact on the environment, but at least one effect 1) has been adequately analyzed in an earlier document pursuant to applicable legal standards, and 2) has been addressed by mitigation measures based on the earlier analysis as described on attached sheets. An **ENVIRONMENTAL IMPACT REPORT** is required, but it must analyze only the effects that remain to be addressed.
- I find that although the proposed project could have a significant effect on the environment, because all potentially significant effects (a) have been analyzed adequately in an earlier EIR or **NEGATIVE DECLARATION** pursuant to applicable standards, and (b) have been avoided or mitigated pursuant to that earlier EIR or **NEGATIVE DECLARATION**, including revisions or mitigation measures that are imposed upon the proposed project, nothing further is required.

---



---

Casey Murray, Senior Planner

---

3-18-2025

---

Date

---



---

Neal Hay, Director of Development Services  
Environmental Control Officer

---

3-24-2025

---

Date

Potentially Significant Impact	Less Than Significant with Mitigation Incorporated	Less Than Significant Impact	No Impact
--------------------------------------	---	------------------------------------	--------------

**I. AESTHETICS.**

Except as provided in Public Resources Code Section 21099, would the project:

- |  |                          |                          |                                     |                                     |
|--|--------------------------|--------------------------|-------------------------------------|-------------------------------------|
| a) Have a substantial adverse effect on a scenic vista?  | <input type="checkbox"/> | <input type="checkbox"/> | <input checked="" type="checkbox"/> | <input type="checkbox"/>            |
| b) Substantially damage scenic resources, including, but not limited to, trees, rock outcroppings, and historic buildings within a state scenic highway?   | <input type="checkbox"/> | <input type="checkbox"/> | <input type="checkbox"/>            | <input checked="" type="checkbox"/> |
| c) In nonurbanized areas, substantially degrade the existing visual character or quality of public views of the site and its surroundings? (Public views are those that are experienced from publicly accessible vantage point). If the project is in an urbanized area, would the project conflict with applicable zoning and other regulations governing scenic quality? | <input type="checkbox"/> | <input type="checkbox"/> | <input checked="" type="checkbox"/> | <input type="checkbox"/>            |
| d) Create a new source of substantial light or glare which would adversely affect day or nighttime views in the area?  | <input type="checkbox"/> | <input type="checkbox"/> | <input checked="" type="checkbox"/> | <input type="checkbox"/>            |

**Responses:**

a) **Less than significant impact.** This project will not have a substantial adverse effect on a scenic vista. The General Plan Technical Background Report identifies geographic features such as the Sutter Buttes, Feather River, Sacramento River, Bear River, and the valley's orchards as scenic resources within the County, which contribute to the County's character. Additionally, the Land Use Element of the General Plan contains specific goals and policies directed at preservation of scenic resources and enhancing design of new development. This project site is not within the Sutter Buttes Overlay Zone, is approximately 0.8 miles east of the Feather River, and is not located in the immediate vicinity of the Bear River or Sacramento River. The proposed project will allow a small special events facility on a site that has historically been used for agricultural operations. Events will take place on an approximate one-acre unused horse-riding arena. Only a barn structure and storage container exist on the property, which are not proposed to be used for events. No new buildings or structures other than a single monument sign are proposed with this project. Therefore, this project will not substantially alter any scenic vista and a less than significant impact is anticipated.

b) **No impact.** This project will not substantially damage scenic resources, including, but not limited to, trees, rock outcroppings, and historic buildings within a state scenic highway because there are no state scenic highway designations in Sutter County. As there are no scenic highways located in Sutter County, no impact is anticipated.

c) **Less than significant impact.** The proposed project is located in a nonurbanized area and will not substantially degrade the existing visual character or quality of public views of the site and its surroundings. The proposed small special event facility is permitted in the AG (Agriculture) District subject to Administrative Permit approval. The requirements to establish such a facility are being followed. The proposed project will allow a small special events facility

on a site that has historically been used for agricultural operations. Events will take place on an approximate one-acre unused horse-riding arena. Only a barn structure and storage container exist on the property, which are not proposed to be used for events. No new buildings or structures other than a single monument sign are proposed with this project.

Events will be limited to 12 per year with one event each month. Events will occur during daylight hours only with maximum hours between 7am and 6pm. Events are proposed to take place either on the third or fourth Sunday of each month. Set-up will take place one day before (Saturday) and taken down on the next day (Monday). The project is surrounded by agriculture fields on all sides. As the project will consist of small temporary events in a rural area, this project will not substantially degrade the existing visual character or quality of public views of the site and its surroundings and a less than significant impact is anticipated.

d) **Less than significant impact.** This project will not create a new source of substantial light or glare which will adversely affect day or nighttime views in the area. The area of the project has low levels of ambient lighting predominately from rural residential and agricultural uses and vehicle headlights on County roads. Wall mounted lighting is located on the existing barn building. A single non-illuminated monument sign is proposed near the property entrance. No new exterior lighting is proposed with this project as events are proposed to take place during daylight hours only. Specifically, events will occur between sunrise and sunset with maximum hours between 7am and 6pm. Some lighting and glare may be generated by vehicle headlights as vehicles leave the site; however, the site is located in a very sparsely populated rural area with very few rural residential uses. The applicant anticipates a maximum of 50 vehicles at each event. Once vehicles have left the area, ambient lighting will return to normal levels. As a result, it is not anticipated that this project will create a new source of substantial light or glare in this area. A less than significant impact is anticipated.

(County of Sutter, General Plan Technical Background Report. 2008)  
 (County of Sutter, Zoning Code. 2024)

Potentially Significant Impact	Less Than Significant with Mitigation Incorporated	Less Than Significant Impact	No Impact
--------------------------------------	---	------------------------------------	--------------

**II. AGRICULTURE AND FORESTRY RESOURCES.**

In determining whether impacts to agricultural resources are significant environmental effects, lead agencies may refer to the California Agricultural Land Evaluation and Site Assessment Model (1997) prepared by the California Dept. of Conservation as an optional model to use in assessing impacts on agriculture and farmland. In determining whether impacts to forest resources, including timberland, are significant environmental effects, lead agencies may refer to information compiled by the California Department of Forestry and Fire Protection regarding the state's inventory of forest land, including the Forest and Range Assessment Project and the Forest Legacy Assessment Project; and forest carbon measurement methodology provided in Forest Protocols adopted by the California Air Resources Board. Would the project:

a) Convert Prime Farmland, Unique Farmland, or

	Potentially Significant Impact	Less Than Significant with Mitigation Incorporated	Less Than Significant Impact	No Impact
Farmland of Statewide Importance (Farmland), as shown on the maps prepared pursuant to the Farmland Mapping and Monitoring Program of the California Resources Agency, to non-agricultural use?				
b) Conflict with existing zoning for agricultural use, or a Williamson Act contract?	<input type="checkbox"/>	<input type="checkbox"/>	<input checked="" type="checkbox"/>	<input type="checkbox"/>
c) Conflict with existing zoning for, or cause rezoning of, forest land (as defined in Public Resources Code Section 12220(g)), timberland (as defined by Public Resources Code Section 4526), or timberland zoned Timberland Production (as defined by Government Code Section 51104(g))?	<input type="checkbox"/>	<input type="checkbox"/>	<input type="checkbox"/>	<input checked="" type="checkbox"/>
d) Result in the loss of forest land or conversion of forest land to non-forest use?	<input type="checkbox"/>	<input type="checkbox"/>	<input type="checkbox"/>	<input checked="" type="checkbox"/>
e) Involve other changes in the existing environment which, due to their location or nature, could result in conversion of Farmland, to non-agricultural use or conversion of forest land to non-forest use?	<input type="checkbox"/>	<input type="checkbox"/>	<input checked="" type="checkbox"/>	<input type="checkbox"/>

**Responses:**

a) **No impact.** This project will not convert Prime Farmland, Unique Farmland, or Farmland of Statewide Importance (Farmland), as shown on the maps prepared pursuant to the Farmland Mapping and Monitoring Program (FMMP) of the California Resources Agency, to a non-agricultural use. As shown on the 2020 Sutter County Important Farmland map, the entire project site and all 60 acres owned by the applicant are designated as "Grazing Land." As a result, no impacts are anticipated.

b) **Less than significant impact.** This project will not conflict with existing zoning for agricultural uses or a Williamson Act contract. The project site and all adjacent properties are not encumbered by a Williamson Act contract. All parcels in the general area and surrounding the project site are zoned AG (Agriculture). The proposed small special event facility is permitted in the AG (Agriculture) District subject to Administrative Permit approval. The requirements to establish such a facility are being followed. The County Agricultural Department reviewed this project and had no comments or concerns.

The proposed project will allow a small special events facility on a site that has historically been used for agricultural operations. Events will take place on an approximate one-acre unused horse-riding arena. Only a barn structure and storage container exist on the property, which are not proposed to be used for events. No new buildings or structures other than a single monument sign are proposed with this project. Events will be limited to 12 per year with one event each month. Conflicts between the proposed project and adjacent agricultural land is not anticipated. A less than significant impact is anticipated.

c) **No impact.** This project does not conflict with existing zoning for, or cause rezoning of, forest land (as defined in Public Resources Code Section 12220(g)), timberland (as defined by Public Resources Code Section 4526), or timberland zoned Timberland Production (as defined by Government Code Section 51104(g)), because the project site and surrounding area does not contain forest land. The project site is not zoned for forest land or timberland nor is it adjacent to land that is zoned for forest land or timberland. This project is located in the Sacramento Valley, a non-forested region. No impact is anticipated.

d) **No Impact.** This project will not result in the loss of forest land or conversion of forest land to a non-forest use because of its location within Sutter County. Sutter County is located on the valley floor of California’s Central Valley, and, as such, does not contain forest land. No impact is anticipated.

e) **Less than significant impact.** This project will not involve other changes to the existing environment which could result in the conversion of farmland to a non-agricultural use or conversion of forest land to a non-forest use. This project does not include land being converted from farmland to a non-agricultural use or forest land to non-forest use. Agricultural uses in the vicinity will continue as they historically have. Staff does not anticipate that this project will result in the conversion of other agricultural lands to non-agricultural use. Therefore, a less than significant impact is anticipated.

(California Dept. of Conservation, Farmland Mapping and Monitoring Program. 2020)  
 (County of Sutter, Zoning Code. 2024)

Potentially Significant Impact	Less Than Significant with Mitigation Incorporated	Less Than Significant Impact	No Impact
--------------------------------------	---	------------------------------------	--------------

**III. AIR QUALITY.**

Where available, the significance criteria established by the applicable air quality management district or air pollution control district may be relied upon to make the following determinations. Would the project:

- |   |                          |                          |                                     |                          |
|---|--------------------------|--------------------------|-------------------------------------|--------------------------|
| a) Conflict with or obstruct implementation of the applicable air quality plan?   | <input type="checkbox"/> | <input type="checkbox"/> | <input checked="" type="checkbox"/> | <input type="checkbox"/> |
| b) Result in a cumulatively considerable net increase of any criteria pollutant for which the project region is non-attainment under an applicable federal or state ambient air quality standard? | <input type="checkbox"/> | <input type="checkbox"/> | <input checked="" type="checkbox"/> | <input type="checkbox"/> |
| c) Expose sensitive receptors to substantial pollutant concentrations?  | <input type="checkbox"/> | <input type="checkbox"/> | <input checked="" type="checkbox"/> | <input type="checkbox"/> |
| d) Result in other emissions (such as those leading to odors) adversely affecting a substantial number of people?   | <input type="checkbox"/> | <input type="checkbox"/> | <input checked="" type="checkbox"/> | <input type="checkbox"/> |

**Responses:**

a-d) **Less than significant impact.** This project will not conflict with or obstruct implementation of an applicable air quality plan, result in a considerable net increase of any criteria pollutant, or

expose sensitive receptors to substantial pollutant concentrations or objectionable odors. Both the federal and State governments have established ambient air quality standards, based on their respective Clean Air Acts, for various air pollutants identified as “criteria” air pollutants. The federal Clean Air Act identifies six criteria pollutants: reactive organic gases (ROG), nitrogen oxides (NOx), carbon monoxide (CO), sulfur dioxide (SO<sub>2</sub>), lead, and particulate matter less than 10 micrometers in diameter (PM<sub>10</sub>), a subset of which is particulate matter less than 2.5 micrometers in diameter (PM<sub>2.5</sub>). The California Clean Air Act identifies these six federal criteria pollutants, along with four others.

Under both Clean Air Acts, air basins are classified as being in “attainment” or “nonattainment” of these ambient air quality standards, or they are “unclassified”. Any air district that has been designated as a nonattainment area relative to federal and/or State ambient air quality standards for ozone, CO, sulfur dioxide, or nitrogen dioxide is required to prepare and submit a plan for attaining and maintaining the standards for which it is in nonattainment.

The proposed project is located within the Northern Sacramento Valley Air Basin (NSVAB) and the jurisdiction of the Feather River Air Quality Management District (FRAQMD), which covers both Sutter and Yuba Counties. Air quality standards are set at both the federal and state levels. FRAQMD is responsible for the planning and maintenance/attainment of these standards at the local level. FRAQMD sets operational rules and limitations for businesses that emit significant amounts of criteria pollutants. The FRAQMD is either in attainment of or unclassified for all federal and State ambient air quality except for federal standards for ozone and PM<sub>10</sub>. Portions of Sutter County are also in nonattainment of State standards for ozone. The FRAQMD, in cooperation with other air districts in the northern Sacramento Valley, has prepared the Northern Sacramento Valley Planning Area Air Quality Attainment Plan for the attainment of State ozone standards. Plans have also been prepared for the attainment of federal ozone and PM<sub>10</sub> standards.

According to the FRAQMD 2010 Indirect Source Review Guidelines, Significant Impact Thresholds are triggered by the construction of projects larger than 130 new single-family residences, 225,000 square feet of new light industrial space, 350,000 square feet of new warehouse space, or 130,000 gross square feet of new office space. This project will not trigger any of these thresholds of significance and as such, will have a less than significant impact upon air quality.

Dust from car traffic will be contained by sprinkling water with tankers prior to the event day as well as regulating onsite speed to a maximum of five miles per hour. Gravel is to be spread in the horse arena to contain dust. This project was circulated to FRAQMD for review and they had no comments but stated that the project applicant is aware of potential dust issues and has controls to be in place for events.

This project does not include any project components identified by the California Air Resources Board that could potentially impact any sensitive receptors. These include heavily traveled roads, distribution centers, fueling stations, and drycleaning operations. The proposed project is located in a remote agricultural area with very few sensitive receptors within proximity to the project site. The nearest residence is located approximately 0.42 miles to the east on a large agricultural parcel. Air quality impacts to sensitive receptors are expected to be less than significant.

The proposed project will not include operation of any odor-generating facilities. Therefore, the project will not be anticipated to generate odors that will affect a substantial number of people.

Overall, because this project will not generate emissions above FRAQMD's thresholds of significance for construction and operational activities, a less than significant impact is anticipated.

(Feather River Air Quality Management District, Indirect Source Review Guidelines. 2010)  
(County of Sutter, General Plan 2030. 2011)

	Potentially Significant Impact	Less Than Significant with Mitigation Incorporated	Less Than Significant Impact	No Impact
<b>IV. BIOLOGICAL RESOURCES.</b> Would the project:				
a) Have a substantial adverse effect, either directly or through habitat modifications, on any species identified as a candidate, sensitive, or special status species in local or regional plans, policies or regulations, or by the California Department of Fish and Wildlife or U.S. Fish and Wildlife Service?	<input type="checkbox"/>	<input type="checkbox"/>	<input checked="" type="checkbox"/>	<input type="checkbox"/>
b) Have a substantial adverse effect on any riparian habitat or other sensitive natural community identified in local or regional plans, policies, regulations, or by the California Department of Fish and Wildlife or U.S. Fish and Wildlife Service?	<input type="checkbox"/>	<input type="checkbox"/>	<input checked="" type="checkbox"/>	<input type="checkbox"/>
c) Have a substantial adverse effect on state or federally protected wetlands (including, but not limited to, marsh, vernal pool, coastal, etc.) through direct removal, filling, hydrological interruption, or other means?	<input type="checkbox"/>	<input type="checkbox"/>	<input checked="" type="checkbox"/>	<input type="checkbox"/>
d) Interfere substantially with the movement of any native resident or migratory fish or wildlife species or with established native resident or migratory wildlife corridors, or impede the use of native wildlife nursery sites?	<input type="checkbox"/>	<input type="checkbox"/>	<input checked="" type="checkbox"/>	<input type="checkbox"/>
e) Conflict with any local policies or ordinances protecting biological resources, such as a tree preservation policy or ordinance?	<input type="checkbox"/>	<input type="checkbox"/>	<input type="checkbox"/>	<input checked="" type="checkbox"/>
f) Conflict with the provisions of an adopted Habitat Conservation Plan, Natural Community Conservation Plan, or other approved local, regional, or state habitat conservation plan?	<input type="checkbox"/>	<input type="checkbox"/>	<input type="checkbox"/>	<input checked="" type="checkbox"/>

**Responses:**

a) **Less than significant impact.** This project will not have a substantial adverse effect, either directly or through habitat modifications, on any species identified as a candidate, sensitive, or special status species in local or regional plans, policies, or regulations, or by the California Department of Fish and Wildlife (CDFW) or U.S. Fish and Wildlife Service (USFWS). The California Natural Diversity Database (CNDDDB) is a positive-sighting database managed by CDFW. According to the CNDDDB, there are no candidate, sensitive, or special status species

identified as potentially occurring on-site or in the immediate area. This project was circulated to CDFW for review, and they did not provide any comments.

The proposed project will allow a small special events facility on a site that has historically been used for agricultural operations. Events will take place on an approximate one-acre unused horse-riding arena. Only a barn structure and storage container exist on the property, which are not proposed to be used for events. No new buildings or structures other than a single monument sign are proposed with this project. Events will be limited to 12 per year with one event each month. Events will occur during daylight hours only with maximum hours between 7am and 6pm. The project is surrounded by agriculture fields on all sides. This project will consist of small temporary events in a rural area. The uses occurring in the area are not conducive for wildlife to locate within the project site and none have been inventoried. Therefore, a less than significant impact is anticipated.

b) **Less than significant impact.** This project will not have a substantial adverse effect on any riparian habitat or other sensitive natural community identified in local or regional plans, policies, regulations, or by the CDFW or USFWS. There are no streams or rivers in the immediate vicinity. No riparian habitat or other sensitive natural community is known to exist on-site or near the property. The site will be directly accessed from West Catlett Road through an existing entrance. Therefore, a less than significant impact is anticipated.

c) **Less than significant impact.** This project will not have a substantial adverse effect on state or federally protected wetlands (including, but not limited to, marsh, vernal pool, coastal, etc.) through direct removal, filling, hydrological interruption, or other means because there are no known wetlands located within the project site. Events will take place on an approximate one-acre unused horse-riding arena. No new buildings or structures other than a single monument sign are proposed with this project. The site will be directly accessed from West Catlett Road through an existing entrance. Therefore, a less than significant impact is anticipated.

d) **Less than significant impact.** This project will not interfere substantially with the movement of any native resident or migratory fish or wildlife species or with established native resident or migratory wildlife corridors or impede the use of a native wildlife nursery site because the area is predominately developed agriculturally with field crops. The project is not anticipated to significantly interfere with wildlife movement due to the fact that the site is bound by West Catlett Road to the north and events will take place within an existing fenced yard. No new buildings or structures other than a single monument sign are proposed with this project. The site will be directly accessed from West Catlett Road through an existing entrance. Therefore, a less than significant impact is anticipated.

e) **No impact.** This project will not conflict with any local policies or ordinances protecting biological resources, such as a tree preservation policy or ordinance. Sutter County has not adopted a tree preservation ordinance; however, General Plan Policy ER 3.7 is in place to preserve native oak trees when possible through the review of discretionary development projects and activities. Policy ER 3.7 also requires a reduction in the loss of oak trees through consideration of tree mitigation and replanting programs. Based on information included in the project application and review of the 2022 aerial photo of the site, there are no oak trees located on the property and no oak trees are proposed to be removed as a result of this project. As a result, no impact is anticipated.

f) **No impact.** The proposed project will not conflict with the provisions of an adopted Habitat Conservation Plan, Natural Community Conservation Plan, or other approved local, regional, or

state habitat conservation plan because a plan has not been adopted that affects this project site. As a result, not impacts are anticipated.

(County of Sutter, General Plan Technical Background Report. 2008)  
 (California Department of Fish and Wildlife, California Natural Diversity Database)  
 (U.S. Fish and Wildlife Service, National Wetlands Inventory, 2024)

	Potentially Significant Impact	Less Than Significant with Mitigation Incorporated	Less Than Significant Impact	No Impact
<b>V. CULTURAL RESOURCES.</b>				
Would the project:				
a) Cause a substantial adverse change in the significance of a historical resource pursuant to §15064.5?	<input type="checkbox"/>	<input type="checkbox"/>	<input checked="" type="checkbox"/>	<input type="checkbox"/>
b) Cause a substantial adverse change in the significance of an archaeological resource pursuant to §15064.5?	<input type="checkbox"/>	<input type="checkbox"/>	<input checked="" type="checkbox"/>	<input type="checkbox"/>
c) Disturb any human remains, including those interred outside of dedicated cemeteries?	<input type="checkbox"/>	<input type="checkbox"/>	<input checked="" type="checkbox"/>	<input type="checkbox"/>

**Responses:**

a-b) **Less than significant impact.** The proposed project will not cause a substantial adverse change in the significance of a historical resource or archaeological resource pursuant to §15064.5. In Section 4.6 of the General Plan Technical Background Report, Figure 4.6-1 does not list the property as being a historic site. There are no unique features or historical resources located on the project site and the property is not located near a cemetery. The project site is not located within the immediate vicinity of the Bear River, Sacramento River, or Feather River. There is no evidence on the project site indicating that historical or archaeological resources exist. No new buildings or structures other than a single monument sign are proposed with this project. The site will be directly accessed from West Catlett Road through an existing entrance. Furthermore, the property has been extensively disturbed to varying depths due to agricultural operations. Therefore, no significant impacts to historical or archaeological resources are anticipated with this project.

c) **Less than significant impact.** This project is not expected to disturb any human remains, including those interred outside of dedicated cemeteries. There are no unique features or historical resources located on the project site and the property is not located near a cemetery. No new buildings or structures other than a single monument sign are proposed with this project. The site will be directly accessed from West Catlett Road through an existing entrance. California Health and Safety Code §7050.5 states that when human remains are discovered, no further site disturbance can occur until the County Coroner has made the necessary findings as to the origin of the remains and their disposition pursuant to Public Resources Code Section 5097.98. If the remains are recognized to be those of a Native American, the coroner shall contact the Native American Heritage Commission (NAHC) within 24 hours.

Public Resources Code §5097.98 states that whenever the NAHC receives notification of a discovery of Native American human remains from a county coroner, it shall immediately notify the most likely descendent from the deceased Native American. The descendants may inspect the site and recommend to the property owner a means for treating or disposing the human remains. If the Commission cannot identify a descendent, or the descendent identified fails to make a recommendation, or the landowner rejects the recommendation of the descendent, the landowner shall rebury the human remains on the property in a location not subject to further disturbance. As a result, a less than significant impact is anticipated.

(County of Sutter, General Plan Technical Background Report. 2008)

	Potentially Significant Impact	Less Than Significant with Mitigation Incorporated	Less Than Significant Impact	No Impact
<b>VI. ENERGY.</b>				
Would the project:				
a) Result in potentially significant environmental impact due to wasteful, inefficient, or unnecessary consumption of energy resources, during project construction or operation?	<input type="checkbox"/>	<input type="checkbox"/>	<input checked="" type="checkbox"/>	<input type="checkbox"/>
b) Conflict with or obstruct a state or local plan for renewable energy or energy efficiency?	<input type="checkbox"/>	<input type="checkbox"/>	<input checked="" type="checkbox"/>	<input type="checkbox"/>

**Responses:**

a-b) **Less than significant impact.** The proposed project will not result in a potentially significant environmental impact due to wasteful, inefficient, or unnecessary consumption of energy resources during project construction or operation or conflict with or obstruct a state or local plan for renewable energy or energy efficiency. The proposed project will allow a small special events facility on a site that has historically been used for agricultural operations. Events will take place on an approximate one-acre unused horse-riding arena. Only a barn structure and storage container exist on the property, which are not proposed to be used for events. No new buildings or structures other than a single monument sign are proposed with this project. Events will be limited to 12 per year with one event each month. Events will occur during daylight hours only with maximum hours between 7am and 6pm. No exterior lighting is proposed or needed for this project. The site will be directly accessed from West Catlett Road through an existing entrance. Overall, the operation of this project will not require the creation of a new source of energy generation. Project operation will have a nominal effect on local and regional energy supplies. It is expected that operation of this project will not be any more inefficient, wasteful, or unnecessary than other similar projects of this nature. This project does not require and will not utilize a substantial amount of energy due to proposed activities. As a result, a less than significant impact is anticipated.

	Potentially Significant Impact	Less Than Significant with Mitigation Incorporated	Less Than Significant Impact	No Impact
--	--------------------------------	--	------------------------------	-----------

**VII. GEOLOGY AND SOILS.**

Would the project:

a) Directly or indirectly cause potential substantial adverse effects, including the risk of loss, injury, or death involving:

i) Rupture of a known earthquake fault, as delineated on the most recent Alquist-Priolo Earthquake Fault Zoning Map issued by the State Geologist for the area or based on other substantial evidence of a known fault? Refer to Division of Mines and Geology Special Publication 42.	<input type="checkbox"/>	<input type="checkbox"/>	<input checked="" type="checkbox"/>	<input type="checkbox"/>
ii) Strong seismic ground shaking?	<input type="checkbox"/>	<input type="checkbox"/>	<input checked="" type="checkbox"/>	<input type="checkbox"/>
iii) Seismic-related ground failure, including liquefaction?	<input type="checkbox"/>	<input type="checkbox"/>	<input checked="" type="checkbox"/>	<input type="checkbox"/>
iv) Landslides?	<input type="checkbox"/>	<input type="checkbox"/>	<input checked="" type="checkbox"/>	<input type="checkbox"/>
b) Result in substantial soil erosion or the loss of topsoil?	<input type="checkbox"/>	<input type="checkbox"/>	<input checked="" type="checkbox"/>	<input type="checkbox"/>
c) Be located on a geological unit or soil that is unstable, or that would become unstable as a result of the project, and potentially result in on- or off-site landslide, lateral spreading, subsidence, liquefaction or collapse?	<input type="checkbox"/>	<input type="checkbox"/>	<input checked="" type="checkbox"/>	<input type="checkbox"/>
d) Be located on expansive soil, as defined in Table 18-1-B of the Uniform Building Code (1994), creating substantial direct or indirect risks to life or property?	<input type="checkbox"/>	<input type="checkbox"/>	<input checked="" type="checkbox"/>	<input type="checkbox"/>
e) Have soils incapable of adequately supporting the use of septic tanks or alternative waste water disposal systems where sewers are not available for the disposal of waste water?	<input type="checkbox"/>	<input type="checkbox"/>	<input type="checkbox"/>	<input checked="" type="checkbox"/>
f) Directly or indirectly destroy a unique paleontological resource or site or unique geologic feature?	<input type="checkbox"/>	<input type="checkbox"/>	<input checked="" type="checkbox"/>	<input type="checkbox"/>

**Responses:**

a) **Less than significant impact.** This project will not directly or indirectly cause potential substantial adverse effects from rupture of a known earthquake fault, strong seismic ground shaking, seismic-related ground failure, including liquefaction, or landslides because the subject property is not located in an Alquist-Priolo Earthquake Fault Zone and will not exacerbate existing seismic hazards in the region. Figure 5.1-1 in the General Plan Technical Background Report does not identify any active earthquake faults in Sutter County as defined by the California Mining and Geology Board. The faults identified in Sutter County include the Quaternary Faults, located in the northern section of the County within the Sutter Buttes, and the Pre-Quaternary Fault, located in the southeastern corner of the County, just east of where Highway 70 enters the County (Figure 5.1-1 of the General Plan Technical Background Report).

Both faults are listed as non-active faults but have the potential for seismic activity. The project site is relatively level with no significant slope and is not in an area where any documented faults exist. The project will involve minor grading activities that will not exacerbate existing seismic hazards in the region and is unlikely to be affected by earthquakes, liquefaction, or landslides in the region. As a result, a less than significant impact is anticipated.

b) **Less than significant impact.** This project will not result in substantial soil erosion or the loss of topsoil. According to the USDA Soil Conservation Service Soil Survey of the County, on-site soils consist of Nueva loam, 0 to 1 percent slopes. These soils are unlikely to cause erosion because runoff is very slow with only a slight hazard of water erosion. The General Plan Technical Background Report indicates that soils with a 0 to 9 percent slope have slight erodibility. The project site is relatively level and has been graded in the past to accommodate agricultural use. Severe erosion typically occurs on moderate slopes of sand and steep slopes of clay subjected to concentrated water runoff. These conditions do not exist at the site. The proposed project will allow a small special events facility on a site that has historically been used for agricultural operations. Events will take place on an approximate one-acre unused horse-riding arena. Only a barn structure and storage container exist on the property, which are not proposed to be used for events. No new buildings or structures other than a single monument sign are proposed with this project. The site will be directly accessed from West Catlett Road through an existing entrance. A less than significant impact is anticipated.

c) **Less than significant impact.** This project is not located on a geological unit or soil that is unstable, or that would become unstable as a result of the project, and potentially result in on- or off-site landslide, lateral spreading, subsidence, liquefaction, or collapse. As stated above in b), soils at the site have a 0 to 1 percent slope with only a slight hazard of water erosion. The General Plan Technical Background Report indicates that soils with a 0 to 9 percent slope have slight erodibility. In addition, the project is not located in the Sutter Buttes, the only area identified by the General Plan Technical Background Report as having landslide potential. A less than significant impact is anticipated.

d) **Less than significant impact.** This project is not located on expansive soil creating substantial direct or indirect risks to life or property. The soil types on the project site, as stated above in b), have a low to moderate shrink-swell potential. The proposed project will allow a small special events facility on a site that has historically been used for agricultural operations. Events will take place on an approximate one-acre unused horse-riding arena. Only a barn structure and storage container exist on the property, which are not proposed to be used for events. No new buildings or structures other than a single monument sign are proposed with this project. The site will be directly accessed from West Catlett Road through an existing entrance. A less than significant impact is anticipated.

e) **No impact.** This project does not have soils incapable of adequately supporting the use of septic tanks or alternative wastewater disposal systems where sewers are not available for the disposal of wastewater. Properties in the area of the project rely on the use of on-site septic tanks and leach field systems for the disposal of wastewater, as there is no sewer system available in the area. The property does not have an existing septic system/leach field and this project does not propose the use of one. Portable restrooms are proposed to be provided for the duration of an event. As a result, no impacts are anticipated.

f) **Less than significant impact.** The proposed project will not directly or indirectly destroy a unique paleontological resource or site or unique geologic feature. There are no known unique paleontological resources or unique geologic features located in the vicinity of the project. The

proposed project will allow a small special events facility on a site that has historically been used for agricultural operations. Events will take place on an approximate one-acre unused horse-riding arena. Only a barn structure and storage container exist on the property, which are not proposed to be used for events. No new buildings or structures other than a single monument sign are proposed with this project. The property has been extensively disturbed to varying depths due to agricultural operations. Given past agricultural operations, it is unlikely that the project site has any intact paleontological resources. A less than significant impact is anticipated.

(County of Sutter, General Plan Technical Background Report. 2008)  
 (USDA Soil Conservation Service, Sutter County Soil Survey. 1988)

**VIII. GREENHOUSE GAS EMISSIONS.**

Would the project:

	Potentially Significant Impact	Less Than Significant with Mitigation Incorporated	Less Than Significant Impact	No Impact
a) Generate greenhouse gas emissions, either directly or indirectly, that may have a significant impact on the environment?	<input type="checkbox"/>	<input type="checkbox"/>	<input checked="" type="checkbox"/>	<input type="checkbox"/>
b) Conflict with an applicable plan, policy or regulation adopted for the purpose of reducing the emissions of greenhouse gases?	<input type="checkbox"/>	<input type="checkbox"/>	<input checked="" type="checkbox"/>	<input type="checkbox"/>

**Responses:**

a) **Less than significant impact.** This project will not generate additional greenhouse gas emissions, either directly or indirectly, that may have a significant impact on the environment. Sutter County is required to reduce greenhouse gas emissions to 1990 levels by the year 2020 consistent with State reduction goals in Assembly Bill (AB) 32. The Climate Action Plan (CAP) was prepared and adopted as part of the General Plan to ensure compliance with AB 32. Sutter County’s CAP includes a greenhouse gas (GHG) inventory, an emission reduction target, and reduction measures to reach the target. The CAP also includes screening tables used to assign points for GHG mitigation measures. Projects that achieve 100 points or more do not need to quantify GHG emissions and are assumed to have a less than significant impact.

Sutter County’s screening tables apply to all project sizes. Small projects with little or no proposed development and minor levels of GHG emissions typically cannot achieve the 100-point threshold and therefore must quantify GHG emission impacts using other methods, an approach that consumes time and resources with no substantive contribution to achieving the CAP reduction target.

Since the adoption of the CAP, further analysis to determine if a project can be too small to provide the level of GHG emissions reductions expected from the screening tables or alternative emissions analysis methods has been performed. In that study, emissions were estimated for each project within the Governor’s Office of Planning and Research (OPR) database. The analysis found that 90 percent of carbon dioxide equivalent (CO<sub>2</sub>e) emissions are from CEQA projects that exceed 3,000 metric tons CO<sub>2</sub>e per year. Both cumulatively and individually,

projects that generate less than 3,000 metric tons CO<sub>2</sub>e per year have a negligible contribution to overall emissions.

Sutter County has concluded that projects generating less than 3,000 metric tons of CO<sub>2</sub>e per year are not required to be evaluated using Sutter County’s screening tables. Such projects require no further GHG emissions analysis and are assumed to have a less than significant impact.

In June 2016, Sutter County adopted new GHG Pre-Screening Measures to be applied to new projects. Based on these Pre-Screening Measures, a Special Events Facility is pre-screened out and determined to comply with the Sutter County CAP and the 3,000-metric-ton Tier 2 screening threshold for CO<sub>2</sub>e if the area utilized is 70,000 square feet (1.6 acres) or less. The proposed area identified by the applicant for holding special events is approximately one acre; therefore, it falls below the threshold. Therefore, no further GHG emissions analysis is required for the proposed project and a less than significant impact is anticipated.

b) **Less than significant impact.** This project will not conflict with an applicable plan, policy, or regulation adopted for the purpose of reducing the emissions of greenhouse gases. The project is within the boundaries of the Feather River Air Quality Management District (FRAQMD), which has not individually adopted any plans or regulations for reducing greenhouse gas emissions. However, FRAQMD adopted a document on August 7, 2015, through the Northern Sacramento Valley Planning Area and in collaboration with Butte County AQMD, Colusa County Air Pollution Control District (APCD), Glenn County APCD, Shasta County AQMD, and Tehama County APCD, titled the 2015 Triennial Air Quality Attainment Plan. This document provides thresholds given by some of the AQMDs and APCDs, and the thresholds given by FRAQMD from 2010, which are described and analyzed in the Air Quality impact section, still apply to Sutter County. In addition, the County has adopted a Climate Action Plan (CAP) that details methods to reduce greenhouse gas emissions. As noted in a) above, this project will be consistent with the County CAP so a less than significant impact is anticipated.

(County of Sutter, General Plan Technical Background Report. 2008)  
 (County of Sutter, General Plan 2030 Climate Action Plan. 2011)  
 (County of Sutter, Greenhouse Gas Pre-Screening Measures for Sutter County. June 28, 2016.)  
 (Sacramento Valley Air Quality Engineering and Enforcement Professionals (SVAQEPP), Northern Sacramento Valley Planning Area 2015 Triennial Air Quality Attainment Plan. 2015)

	Potentially Significant Impact	Less Than Significant with Mitigation Incorporated	Less Than Significant Impact	No Impact
<b>IX. HAZARDS AND HAZARDOUS MATERIALS.</b>				
Would the project:				
a) Create a significant hazard to the public or the environment through the routine transport, use, or disposal of hazardous materials?	<input type="checkbox"/>	<input type="checkbox"/>	<input type="checkbox"/>	<input checked="" type="checkbox"/>
b) Create a significant hazard to the public or the environment through reasonably foreseeable upset and accident conditions involving the release of hazardous materials into the environment?	<input type="checkbox"/>	<input type="checkbox"/>	<input type="checkbox"/>	<input checked="" type="checkbox"/>
c) Emit hazardous emissions or handle hazardous or	<input type="checkbox"/>	<input type="checkbox"/>	<input type="checkbox"/>	<input checked="" type="checkbox"/>

	Potentially Significant Impact	Less Than Significant with Mitigation Incorporated	Less Than Significant Impact	No Impact
acutely hazardous materials, substances, or waste within one-quarter mile of an existing or proposed school?				
d) Be located on a site which is included on a list of hazardous materials sites compiled pursuant to Government Code § 65962.5 and, as a result, would it create a significant hazard to the public or the environment?	<input type="checkbox"/>	<input type="checkbox"/>	<input type="checkbox"/>	<input checked="" type="checkbox"/>
e) For a project located within an airport land use plan or, where such a plan has not been adopted, within two miles of a public airport or public use airport, would the project result in a safety hazard or excessive noise for people residing or working in the project area?	<input type="checkbox"/>	<input type="checkbox"/>	<input type="checkbox"/>	<input checked="" type="checkbox"/>
f) Impair implementation of or physically interfere with an adopted emergency response plan or emergency evacuation plan?	<input type="checkbox"/>	<input type="checkbox"/>	<input checked="" type="checkbox"/>	<input type="checkbox"/>
g) Expose people or structures, either directly or indirectly, to a significant risk of loss, injury or death involving wildland fires?	<input type="checkbox"/>	<input type="checkbox"/>	<input checked="" type="checkbox"/>	<input type="checkbox"/>

**Responses:**

a-b) **No impact.** This project will not create a significant hazard to the public or the environment through the routine transport, use, or disposal of hazardous materials, or the creation of a significant hazard to the public or the environment through reasonably foreseeable upset and accident conditions involving the release of hazardous materials into the environment. The project consists of a small outdoor special event facility with only one event allowed per month (12 events per year). The Development Services Environmental Health Division is the Certified Unified Program Agency (CUPA) for Sutter County with responsibility for the administration of the “Unified Hazardous Waste and Hazardous Materials Management Regulatory Program” (Unified Program). All uses involving the storage and handling of hazardous materials are monitored by CUPA. CUPA has reviewed this project and stated that they had no comments. This project does involve the routine transport, use, or disposal of hazardous materials. No impact is anticipated.

c) **No impact.** This project will not emit hazardous emissions or handle hazardous or acutely hazardous materials, substances, or waste within one-quarter mile of an existing or proposed school. The site is located in a very sparsely populated rural area with very few rural residential uses. The closest existing school is located approximately five miles northwest of the site in the community of Robbins. There are no proposed schools within the vicinity of the project site. The proposed project will not result in any hazard through the transport, use, or disposal of hazardous waste. Due to the nature of this project, no impacts are anticipated.

d) **No impact.** This project is not located on a site which is included on a list of hazardous materials sites compiled pursuant to Government Code §65962.5. As a result, the project will not create a hazard to the public or the environment; therefore, no impact is anticipated.

e) **No impact.** This project is not located within two miles of a public airport or public use airport; therefore, this project will not result in a safety hazard or excessive noise for people residing or working in the project area. The nearest public airport to the project site is Sacramento International Airport, approximately nine miles to the southeast. This project is located within the Airport Influence Area of the Sacramento International Airport Comprehensive Land Use Plan (ALUCP), which would typically require the project to be reviewed by the appropriate Airport Land Use Commission. For Sacramento International Airport, the Commission would be the Sacramento Area Council of Governments (SACOG).

However, the ALUCP also places the project site within Referral Area 2. Referral Area 2 includes areas where airspace protection and/or overflight are compatibility concerns, but not noise or safety. Only projects with any proposed object having a height that requires review by the Federal Aviation Administration, the potential to create electrical or visual hazards to aircraft in flight, or the potential to create a thermal plume extending to an altitude where aircraft fly would be subject to Airport Land Use Commission review. This project does not meet any of these conditions. Moreover, the project site is not within any of the safety zones established for the airport by the ALUCP. Therefore, the project is not expected to result in a safety hazard or excessive noise for people residing or working in the project area. No impact is anticipated.

f) **Less than significant impact.** This project will not impact the implementation of, or physically interfere with, an adopted emergency response plan or emergency evacuation plan because the project site has adequate frontage on West Catlett Road, which is of sufficient size to not impede necessary emergency responses or evacuations. This project does not pose a unique or unusual use or activity that will impair the effective and efficient implementation of an adopted emergency response or evacuation plan. A less than significant impact is anticipated.

g) **Less than significant impact.** This project will not expose people or structures, either directly or indirectly, to a significant risk of loss, injury, or death involving wildland fires. The General Plan indicates the Sutter Buttes and the “river bottoms,” or those areas along the Sacramento, Feather, and Bear Rivers within the levee system, are susceptible to wildfires since much of the areas inside the levees are left in a natural state, thereby allowing combustible fuels to accumulate over long periods of time. The area has existing fire protection services. Since this property is not located in the Sutter Buttes or “river bottom” areas, a significant risk of loss, injury, or death associated with wildland fires as a result of the proposed project is not anticipated and is considered less than significant.

(County of Sutter, General Plan Technical Background Report. 2008)  
 (California Department of Toxic Substances Control, Hazardous Waste and Substances Site List - Site Cleanup (Cortese List). 2024)  
 (Sacramento Area Council of Governments, Sacramento International Airport Land Use Compatibility Plan. 2013)

Potentially Significant Impact	Less Than Significant with Mitigation Incorporated	Less Than Significant Impact	No Impact
--------------------------------	--	------------------------------	-----------

**X. HYDROLOGY AND WATER QUALITY.**

Would the project:

a) Violate any water quality standards or waste discharge requirements or otherwise substantially degrade surface or ground water quality?

	Potentially Significant Impact	Less Than Significant with Mitigation Incorporated	Less Than Significant Impact	No Impact
b) Substantially decrease groundwater supplies or interfere substantially with groundwater recharge such that the project may impede sustainable groundwater management of the basin?	<input type="checkbox"/>	<input type="checkbox"/>	<input checked="" type="checkbox"/>	<input type="checkbox"/>
c) Substantially alter the existing drainage pattern of the site or area, including through the alteration of the course of a stream or river or through the addition of impervious surfaces, in a manner which would:				
i) Result in substantial erosion or siltation on- or off-site;	<input type="checkbox"/>	<input type="checkbox"/>	<input checked="" type="checkbox"/>	<input type="checkbox"/>
ii) Substantially increase the rate or amount of surface runoff in a manner which would result in flooding on- or off-site;	<input type="checkbox"/>	<input type="checkbox"/>	<input checked="" type="checkbox"/>	<input type="checkbox"/>
iii) Create or contribute runoff water which would exceed the capacity of existing or planned stormwater drainage systems or provide substantial additional sources of polluted runoff; or	<input type="checkbox"/>	<input type="checkbox"/>	<input checked="" type="checkbox"/>	<input type="checkbox"/>
iv) Impede or redirect flood flows?	<input type="checkbox"/>	<input type="checkbox"/>	<input checked="" type="checkbox"/>	<input type="checkbox"/>
d) In flood hazard, tsunami, or seiche zones, risk release of pollutants due to project inundation?	<input type="checkbox"/>	<input type="checkbox"/>	<input checked="" type="checkbox"/>	<input type="checkbox"/>
e) Conflict with or obstruct implementation of a water quality control plan or sustainable groundwater management plan?	<input type="checkbox"/>	<input type="checkbox"/>	<input type="checkbox"/>	<input checked="" type="checkbox"/>

**Responses:**

a) **Less than significant impact.** This project will not violate any water quality standards or waste discharge requirements or otherwise substantially degrade surface or ground water quality. The proposed project will allow a small special events facility on a site that has historically been used for agricultural operations. Events will take place on an approximate one-acre unused horse-riding arena. Only a barn structure and storage container exist on the property, which are not proposed to be used for events. No new buildings or structures other than a single monument sign are proposed with this project. The site will be directly accessed from West Catlett Road through an existing entrance. The property does not have an existing septic system/leach field and this project does not propose the use of one. The project proposes to provide portable restrooms with handwashing stations and bottled water for events. This project is not expected to violate water quality standards or waste discharge requirements. Compliance with applicable requirements and water quality standards will minimize the project's impact to water quality. A less than significant impact is anticipated.

b) **Less than significant impact.** This project will not substantially decrease groundwater supplies or interfere substantially with groundwater recharge such that the project may impede sustainable groundwater management of the basin. The project proposes to provide portable

restrooms with handwashing stations and bottled water for events. A water truck will be used for dust control. No new wells are proposed as part of this project. The project is not expected to increase groundwater usage. A less than significant impact is anticipated.

c) **Less than significant impact.** This project will not substantially alter the existing drainage pattern of the site or area, including through the alteration of the course of a stream or river or through the addition of impervious surfaces, in a manner which would result in substantial erosion or siltation on or off site or substantially increase the rate or amount of surface runoff in a manner resulting in flooding on or off-site. This project will also not contribute runoff water which will exceed the capacity of existing or planned stormwater drainage systems or provide substantial additional sources of polluted runoff or impede or redirect flood flows.

There are no streams or rivers on or in the immediate vicinity of the project site that could be altered by this project. The property is not located in an area served by a public stormwater drainage system. The Development Services Engineering Division has reviewed this proposed project with regard to drainage and had no comments. The proposed project will allow a small special events facility on a site that has historically been used for agricultural operations. Events will take place on an approximate one-acre unused horse-riding arena. Only a barn structure and storage container exist on the property, which are not proposed to be used for events. No new buildings or structures other than a single monument sign are proposed with this project. The site will be directly accessed from West Catlett Road through an existing entrance. Minimal construction will result with this project; therefore, this project is not expected to substantially alter the existing drainage pattern of the site or area.

The subject property currently drains to the northeast. A small drainage ditch is located on the east side of the property along Vernon Road. No new paving (other than two accessible parking spaces and driveway entrance) or buildings are proposed for this project, hence existing drainage will not be affected.

The project site is located within Flood Zone "A" according to Flood Insurance Rate Map (FIRM) No. 0603940805E, dated December 1, 2008, issued by the Federal Emergency Management Agency (FEMA). Flood Zone "A" is one of the Special Flood Hazard Areas (SFHAs) and consists of areas subject to inundation by the 1-percent-annual-chance flood event. The site is also located within a Local Flood Hazard Area (LFHA). The Base Flood Elevation (BFE) is approximately 42.3 feet (NAVD) for this area and the ground elevation is approximately 24 feet (NAVD). Any new building at this site would be required to be elevated approximately 19.3 feet in order to be one foot above the BFE; however, no building construction is proposed with this project. A less than significant impact is anticipated.

d) **Less than significant impact.** This project will not risk release of pollutants due to project inundation in flood hazard, tsunami, or seiche zones. The proposed project to permit a small special event facility is not anticipated to risk the release of pollutants due to project inundation in a flood hazard area. The proposed project will allow a small special events facility on a site that has historically been used for agricultural operations. Events will take place on an approximate one-acre unused horse-riding arena. Only a barn structure and storage container exist on the property, which are not proposed to be used for events. No new buildings or structures other than a single monument sign are proposed with this project. The site will be directly accessed from West Catlett Road through an existing entrance. There is no anticipated impact to this project site resulting from tsunamis and seiches because the land is not located adjacent to or near any water bodies of sufficient size to create such situations. A less than significant impact is anticipated.

e) **No Impact.** This project will not conflict with or obstruct implementation of a water quality control plan or sustainable groundwater management plan. There are no currently adopted water quality control plans covering the project site. In addition, this project will not generate significant water demand. No impact is anticipated.

(California Department of Water Resources (DWR), California’s Groundwater – Bulletin 118 (Update 2003). 2003)

(County of Sutter, General Plan Technical Background Report. 2008)

(Federal Emergency Management Agency, Flood Insurance Rate Map. 2008)

(Sutter Subbasin Groundwater Management Coordination Committee, Sutter Subbasin Groundwater Sustainability Plan. 2022)

	Potentially Significant Impact	Less Than Significant with Mitigation Incorporated	Less Than Significant Impact	No Impact
<b>XI. LAND USE AND PLANNING.</b>				
Would the project:				
a) Physically divide an established community?	<input type="checkbox"/>	<input type="checkbox"/>	<input type="checkbox"/>	<input checked="" type="checkbox"/>
b) Cause a significant environmental impact due to a conflict with any land use plan, policy, or regulation adopted for the purpose of avoiding or mitigating an environmental effect?	<input type="checkbox"/>	<input type="checkbox"/>	<input checked="" type="checkbox"/>	<input type="checkbox"/>

**Responses:**

a) **No impact.** This project will not physically divide an established community because the project is located outside the Live Oak and Yuba City spheres of influence and the County’s recognized rural communities. This project is located in the southern portion of Sutter County in a predominantly agricultural area. This project will not modify any existing roadways that will result in a barrier to other surrounding parcels as a result of the project. This project will not result in a physical barrier that will divide a community so no impact is anticipated.

b) **Less than significant impact.** This project will not conflict with an applicable land use plan, policy, or regulation adopted for the purpose of avoiding or mitigating an environmental effect because this project involves the necessary entitlements to allow for this project. As per the Zoning Code, the small outdoor special event facility is permitted in the AG (Agriculture) District subject to Administrative Permit approval. The requirements to establish such a facility are being followed. The County has not adopted any land use plan, policy, or regulation for the purpose of avoiding or mitigating a specific environmental effect that affects this project. The proposed project is consistent with the goals and policies of the General Plan and County Code and will not conflict with any adopted plan affecting the site. A less than significant impact is anticipated.

(County of Sutter, General Plan 2030. 2011)

(County of Sutter, General Plan Technical Background Report. 2008)

(County of Sutter, Zoning Code. 2024)

Potentially Significant Impact	Less Than Significant with Mitigation Incorporated	Less Than Significant Impact	No Impact
--------------------------------	--	------------------------------	-----------

**XII. MINERAL RESOURCES.**

Would the project:

- |   |                          |                          |                          |                                     |
|---|--------------------------|--------------------------|--------------------------|-------------------------------------|
| a) Result in the loss of availability of a known mineral resource that would be of value to the region and the residents of the state?                                | <input type="checkbox"/> | <input type="checkbox"/> | <input type="checkbox"/> | <input checked="" type="checkbox"/> |
| b) Result in the loss of availability of a locally-important mineral resource recovery site delineated on a local general plan, specific plan or other land use plan? | <input type="checkbox"/> | <input type="checkbox"/> | <input type="checkbox"/> | <input checked="" type="checkbox"/> |

**Responses:**

a-b) **No impact.** This project will not result in the loss of availability of a known mineral resource that would be of value to the region and the residents of the state or the loss of availability of a locally-important mineral resource recovery site delineated on a local general plan, specific plan, or other land use plan. The General Plan and State of California Division of Mines and Geology Special Publication 132 do not list the site as having any substantial mineral deposits of a significant or substantial nature, nor is the site located in the vicinity of any existing surface mines. No impact is anticipated.

(California Department of Conservation, Division of Mines and Geology, Special Report 132: Mineral Land Classification: Portland Cement Concrete-Grade Aggregate in the Yuba City-Marysville Production-Consumption Region. 1988)  
 (County of Sutter, General Plan Technical Background Report. 2008)

Potentially Significant Impact	Less Than Significant with Mitigation Incorporated	Less Than Significant Impact	No Impact
--------------------------------	--	------------------------------	-----------

**XIII. NOISE.**

Would the project result in:

- |   |                          |                          |                                     |                          |
|---|--------------------------|--------------------------|-------------------------------------|--------------------------|
| a) Generation of a substantial temporary or permanent increase in ambient noise levels in the vicinity of the project in excess of standards established in the local general plan or noise ordinance, or applicable standards of other agencies?   | <input type="checkbox"/> | <input type="checkbox"/> | <input checked="" type="checkbox"/> | <input type="checkbox"/> |
| b) Generation of excessive groundborne vibration or groundborne noise levels?   | <input type="checkbox"/> | <input type="checkbox"/> | <input checked="" type="checkbox"/> | <input type="checkbox"/> |
| c) For a project located within the vicinity of a private airstrip or an airport land use plan or, where such a plan has not been adopted, within two miles of a public airport or public use airport, would the project expose people residing or working in the project area to excessive noise levels? | <input type="checkbox"/> | <input type="checkbox"/> | <input checked="" type="checkbox"/> | <input type="checkbox"/> |

**Responses:**

a-b) **Less than significant impact.** This project will not result in exposure of persons to, or generation of, noise levels in excess of standards established in the local general plan or noise ordinances, or applicable standards of other agencies or result in exposure of persons to, or generation of, excessive groundborne vibration or groundborne noise levels. The Sutter County General Plan Noise Element provides a basis for local policies to control and abate environmental noise and to protect the citizens of Sutter County from excessive noise exposure. The Sutter County Noise Ordinance (Article 21.5 of the Zoning Code) establishes standards and procedures to protect the health and safety of County residents from the harmful effects of exposure to excessive, unnecessary, or offensive noise. The proposed project is required to operate in a manner that complies with the noise ordinance.

Due to the subject property's rural location, the ambient noise level in the area is expected to be relatively low with occasional noise from operation of agricultural equipment in the area, noise associated with typical rural residential use, and noise from vehicles occasionally driving by the property along West Catlett Road.

The proposed project is located in a remote agricultural area with very few sensitive receptors within proximity to the project site. The surrounding uses consists of field crops. The nearest residence is located approximately 0.42 miles to the east on a large agricultural parcel. Noise impacts to sensitive receptors are expected to be less than significant. In addition, the applicant has stated that they have discussed this proposed project with adjacent property owners.

Construction activities including minor grading and paving will temporarily increase noise levels in the project vicinity. Noise levels will fluctuate depending upon construction activity, equipment type, and duration of use, and the distance between noise source and receiver. General Plan Policy N 1.6 requires discretionary projects to limit noise-generating construction activities within 1,000 feet of noise-sensitive uses, such as residences, to specific daytime hours during weekdays and on Saturdays, and prohibits construction on Sundays and holidays unless permission for the latter has been applied for and granted by the County. The location of the proposed special event facility is not located within 1,000 feet of a noise-sensitive use. The closest existing residence is located approximately 0.42 miles (2,217.60 feet) to the east. Noise impacts associated with construction activities are expected to be less than significant.

The proposed project will allow a small special events facility on a site that has historically been used for agricultural operations. Events will take place on an approximate one-acre unused horse-riding arena. Only a barn structure and storage container exist on the property, which are not proposed to be used for events. No new buildings or structures other than a single monument sign are proposed with this project. Events will be limited to 12 per year with one event each month. Events will occur during daylight hours only with maximum hours between 7am and 6pm. Events are proposed to take place either on the third or fourth Sunday of each month. Set-up will take place one day before (Saturday) and taken down on the next day (Monday). The project is surrounded by agriculture fields on all sides. The project will consist of small temporary events in a rural area. The site will be directly accessed from West Catlett Road through an existing entrance through a 22-foot-wide access gate. No new paving (other than two accessible parking spaces and driveway entrance) or buildings are proposed for this project.

The main source of noise at these events is anticipated to be produced from amplified sound systems during events. Noise levels from amplified sound systems vary considerably and depend upon the size of the area intended to be served, the crowd size, and the nature of the amplified sound (e.g. music versus voice announcements). Article 21.5, Noise Control, of the

Sutter County Zoning Code establishes standards and procedures to protect the health and safety of County residents from harmful effects of exposure to excessive, unnecessary, or offensive noise. Section 1500-21.50-070 D. Temporary Activities and Events, provides an exemption from the Noise Control Ordinance for authorized outdoor or indoor events, gatherings, shows, bands, fairs, festivals, weddings, sporting events entertainment and similar events provided such activities take place between 7:00 a.m. to 10:00 p.m. and do not exceed an Leq of 65 dBA when measured at any point on the property line over any 30-minute period.

All events will be held in context of religious rituals of Sikh faith. Standard speakers and microphones will be used for chanting and singing of hymns from Sikh scriptures, such that event sound remains within property lines. Events will occur during daylight hours only with maximum hours between 7am and 6pm. The proposed facility will be required to comply with Article 21.5 of the Zoning Code, which will be included as a condition of approval.

The project area is not a densely populated area and consists predominately of field crops. This project is not anticipated to significantly increase noise beyond the conditions which already exist in this area; therefore, a less than significant impact is anticipated.

c) **Less than significant impact.** This project is not located within the vicinity of a private airstrip, public airport, or public use airport; therefore, it will not result in excessive noise levels for people residing or working in the project area. As noted in Section IX, Hazards and Hazardous Materials, the nearest public airport is the Sacramento International Airport, located approximately nine miles southeast of the project site. The project site is outside all the noise contours designated in the Sacramento International ALUCP, including the outermost 60-dB CNEL contour. Moreover, the project site is within the ALUCP Referral Area 2, which includes areas where airspace protection and/or overflight are compatibility concerns, but not noise or safety.

The closest private airstrip is located approximately 2.10 miles to the east. Given the airstrip alignment away from the project site and the distance to the airstrip, users of the special event facility are unlikely to experience significant noise from airstrip operations. A less than significant impact from airport and airstrip noise is anticipated.

- (County of Sutter, General Plan 2030. 2011)
- (County of Sutter, General Plan Technical Background Report. 2008)
- (County of Sutter, Zoning Code. 2024)
- (Sacramento Area Council of Governments, Sacramento International Airport Land Use Compatibility Plan. 2013)

Potentially Significant Impact	Less Than Significant with Mitigation Incorporated	Less Than Significant Impact	No Impact
--------------------------------------	---	------------------------------------	--------------

**XIV. POPULATION AND HOUSING.**

Would the project:

- |   |                          |                          |                                     |                          |
|---|--------------------------|--------------------------|-------------------------------------|--------------------------|
| a) Induce substantial unplanned population growth in an area, either directly (for example, by proposing new homes and businesses) or indirectly (for example, through extension of roads or other infrastructure)? | <input type="checkbox"/> | <input type="checkbox"/> | <input checked="" type="checkbox"/> | <input type="checkbox"/> |
|---|--------------------------|--------------------------|-------------------------------------|--------------------------|

Potentially Significant Impact	Less Than Significant with Mitigation Incorporated	Less Than Significant Impact	No Impact
<input type="checkbox"/>	<input type="checkbox"/>	<input type="checkbox"/>	<input checked="" type="checkbox"/>

b) Displace substantial numbers of existing people or housing, necessitating the construction of replacement housing elsewhere?

**Responses:**

a) **Less than significant impact.** This project will not induce substantial unplanned population growth in an area, directly or indirectly. No residential use is proposed with this project so there will be no direct population impacts. There will not be any new full-time employees that may relocate to the area and cause substantial population growth in the area. As a result, the population growth in the area will be negligible or nonexistent and a less than significant impact is anticipated.

b) **No impact.** This project will not displace substantial numbers of people or existing housing, necessitating the construction of replacement housing elsewhere. The proposed project will not expand beyond the property boundaries and will not displace any housing or people. No housing exists at the project site and no replacement housing will be required as part of this project. No impact is anticipated.

(County of Sutter, General Plan Technical Background Report. 2008)

Potentially Significant Impact	Less Than Significant with Mitigation Incorporated	Less Than Significant Impact	No Impact
--------------------------------	--	------------------------------	-----------

**XV. PUBLIC SERVICES.**

Would the project:

a) Result in substantial adverse physical impacts associated with the provision of new or physically altered governmental facilities, need for new or physically altered governmental facilities, the construction of which could cause significant environmental impacts, in order to maintain acceptable service ratios, response times or other performance objectives for any of the public services:

i) Fire protection?	<input type="checkbox"/>	<input type="checkbox"/>	<input checked="" type="checkbox"/>	<input type="checkbox"/>
ii) Police protection?	<input type="checkbox"/>	<input type="checkbox"/>	<input checked="" type="checkbox"/>	<input type="checkbox"/>
iii) Schools?	<input type="checkbox"/>	<input type="checkbox"/>	<input type="checkbox"/>	<input checked="" type="checkbox"/>
iv) Parks?	<input type="checkbox"/>	<input type="checkbox"/>	<input type="checkbox"/>	<input checked="" type="checkbox"/>
v) Other public facilities?	<input type="checkbox"/>	<input type="checkbox"/>	<input checked="" type="checkbox"/>	<input type="checkbox"/>

**Responses:**

i) **Less than significant impact.** This project location is provided fire protection by Sutter County and is located in County Service Area (CSA) D. The nearest fire station is Pleasant Grove (Station 9), located at 3100 Howsley Road, approximately 6.30 miles southeast of the project site. Referral of this project was sent to the Sutter County Fire Department and the Fire Department stated no comment with regard to this project. This project is not anticipated to affect response time for fire protection services. Existing County roads will provide adequate transportation routes to reach the project site in the event of a fire. No new building construction is proposed by this project. A less than significant impact to fire services is anticipated.

ii) **Less than significant impact.** This project will not have a significant impact on police protection. Law enforcement for unincorporated portions of Sutter County is provided by the Sutter County Sheriff's Department and traffic investigation services by the California Highway Patrol. The Sheriff's Department has reviewed this project and had no comments or concerns. This project is not anticipated to affect response time for law enforcement services. Existing State Highways or County roads will provide adequate transportation routes to reach the project site in the event of an emergency. As a result, a less than significant impact is anticipated.

iii) **No impact.** This project will not have a significant impact on schools because this project will not generate additional demand for school services. No new buildings or residences are proposed with this project, so there will be no increase in the number of students. The project is located within the East Nicolaus Joint Union High School District and Marcum-Illinois Union School District. No comments were provided by either school district regarding this project. No impact is anticipated.

iv) **No impact.** This project will not have a significant impact upon parks because it will not generate a need for additional park land or create an additional impact upon existing parks in the region. This project will not have a significant impact on parks countywide. This project will not result in any new residences which require park services; therefore, no impact is anticipated.

v) **Less than significant impact.** There are a limited number of other public facilities in the area that may be impacted by this project; however, potential impacts to general government, library, and health and social services are not anticipated. No new buildings or residences are proposed with this project that would generate a demand for other public services. A less than significant impact is anticipated.

(County of Sutter, Zoning Code. 2024)

(County of Sutter, General Plan Technical Background Report. 2008)

	Potentially Significant Impact	Less Than Significant with Mitigation Incorporated	Less Than Significant Impact	No Impact
<b>XVI. RECREATION.</b>				
a) Would the project increase the use of existing neighborhood and regional parks or other recreational facilities such that substantial physical deterioration of the facility would occur or be accelerated?	<input type="checkbox"/>	<input type="checkbox"/>	<input type="checkbox"/>	<input checked="" type="checkbox"/>
b) Does the project include recreational facilities or require the construction or expansion of recreational facilities which might have an adverse physical effect on the environment?	<input type="checkbox"/>	<input type="checkbox"/>	<input type="checkbox"/>	<input checked="" type="checkbox"/>

**Responses:**

a-b) **No impact.** This project will not increase the use of existing neighborhood and regional parks or other recreational facilities such that substantial physical deterioration of the facility will occur or be accelerated, nor will the project include recreational facilities or require the construction or expansion of recreational facilities which might have an adverse physical effect on the environment. This project will not result in new residential development. There are no existing neighborhood or regional parks in the project vicinity and this project does not propose recreational facilities or require the expansion of existing recreational facilities; therefore, no impacts are anticipated.

(County of Sutter, General Plan Technical Background Report. 2008)

	Potentially Significant Impact	Less Than Significant with Mitigation Incorporated	Less Than Significant Impact	No Impact
<b>XVII. TRANSPORTATION.</b>				
Would the project:				
a) Conflict with a program, plan, ordinance or policy addressing the circulation system, including transit, roadway, bicycle and pedestrian facilities?	<input type="checkbox"/>	<input type="checkbox"/>	<input checked="" type="checkbox"/>	<input type="checkbox"/>
b) Conflict or be inconsistent with CEQA Guidelines § 15064.3, subdivision (b)?	<input type="checkbox"/>	<input type="checkbox"/>	<input checked="" type="checkbox"/>	<input type="checkbox"/>
c) Substantially increase hazards due to a geometric design feature (e.g., sharp curves or dangerous intersections) or incompatible uses (e.g., farm equipment)?	<input type="checkbox"/>	<input type="checkbox"/>	<input checked="" type="checkbox"/>	<input type="checkbox"/>
d) Result in inadequate emergency access?	<input type="checkbox"/>	<input type="checkbox"/>	<input checked="" type="checkbox"/>	<input type="checkbox"/>

**Responses:**

a) **Less than significant impact.** This project will not conflict with a program, plan, ordinance, or policy addressing the circulation system, including transit, roadway, bicycle, and pedestrian facilities. This property is located in a rural area and is not served by mass transit. There are no designated pedestrian or bicycle routes in the area. The project site fronts West Catlett Road, which is a County maintained road. The General Plan classifies West Catlett Road as a Rural Minor Collector. Given the rural location of this property, personal vehicles will be the primary form of transportation.

The site will be directly accessed from West Catlett Road through an existing entrance through a 22-foot-wide access gate that leads to the designated parking area. The driveway connection to West Catlett Road will be required to be paved within the County right-of-way, which will require approval of an encroachment permit from the County.

The applicant was required to submit a traffic study to analyze the project’s potential traffic impacts to specific area roads and intersections. The traffic study was prepared by Wood Rodgers and is included as Attachment 3 to this initial study. As stated in the traffic study, based on an assumed vehicle occupancy of 2.5 persons per vehicle for guests and 1.0 persons per

vehicle for volunteers, the site could generate up to 45 trips before an event (40 guest trips and 5 volunteer trips) and 45 trips after an event (40 guest trips and 5 volunteer trips), resulting in a daily trip generation of 90 trips.

Project trips will generally access the surrounding regional roadway network via the West Catlett Road intersection with State Route 99 (SR 99). Assuming that 50% of project trips travel to/from the Sacramento region (SR 99 south of West Catlett Road) and 50% of project trips travel to/from the Yuba City region (SR 99 north of West Catlett Road), the West Catlett Road intersection with northbound/southbound SR 99 will experience up to 40 project trips during the event arrival hour and event departure hours.

For each time period, half of the estimated project trips (approximately 20 trips) will be making a free right-turn onto West Catlett Road (southbound right) or Southbound SR 99 (eastbound right-turn), therefore contributing minimal delay to the West Catlett Road & northbound/southbound SR 99 intersection. As the project will generate only up to 40 "event hour" trips, and monthly events are likely to occur outside of peak commute hours, the project is not anticipated to adversely affect operations of West Catlett Road or the SR 99 & West Catlett Road intersection.

The increase in traffic is not considered significant in relation to the existing traffic volumes or road capacities and will not reduce the existing LOS of West Catlett Road. The General Plan has a policy (Policy M 2.5) to maintain roads at an LOS D or better during peak hour, and LOS C or better at all other times; therefore, this project is consistent with this policy. No impacts have been identified by the Development Services Engineering Division or Fire Services. Based on the information provided above, a less than significant impact is anticipated.

b) **Less than significant impact.** This project will not conflict or be inconsistent with CEQA Guidelines §15064.3, subdivision (b). This section of CEQA states that vehicle miles traveled (VMT) is the most appropriate measure of transportation impacts. VMT refers to the amount and distance of automobile travel attributable to a project. VMT generally represents the number of vehicle trips generated by a project multiplied by the average trip length for those trips. OPR's Technical Advisory further clarifies that "the term 'automobile' refers to on-road passenger vehicles, specifically cars and light trucks." This section also states VMT exceeding an applicable threshold of significance may indicate a significant impact.

The County has not adopted a threshold of significance for VMT. The traffic study prepared by Wood Rodgers (Attachment 3) includes a VMT screening analysis and uses the guidance in the Governor's Office of Planning and Research's (OPR's) Technical Advisory for the assessment.

Senate Bill (SB) 743 governs the application of new CEQA guidelines for addressing transportation impacts based on VMT. Because Sutter County has not yet adopted guidelines or policies for dealing with VMT, guidance from OPR's Technical Advisory was employed to evaluate VMT impacts. Screening criteria can be used to quickly identify whether sufficient evidence exists to presume a project will have a less than significant VMT impact without conducting a detailed study. Projects meeting at least one of the screening criteria can be presumed to have a less than significant VMT impact, absent substantial evidence that the project will lead to a significant impact.

Small projects that generate or attract fewer than 110 trips per day generally may be assumed to cause a less than significant transportation impact. As stated in the traffic study, the proposed project is estimated to generate 90 daily trips, which is fewer than 110 daily trips on event days.

Since events will only be held once a month, the annual average daily trips generated by the project will be only approximately three trips per day (90 event day trips x 12 events per year / 365 days per year). Based on the analysis included in the traffic study, the project's VMT impacts can be presumed to be less than significant.

c-d) **Less than significant impact.** This project will not substantially increase hazards due to a geometric design feature (e.g., sharp curves or dangerous intersections) or incompatible uses (e.g., farm equipment) nor will it result in inadequate emergency access. The project site has adequate frontage on West Catlett Road, which is a County maintained road. West Catlett Road runs in a straight direction along the frontage of the project site. County roads will provide adequate emergency service access. The traffic study prepared for this project reviewed trip distribution and traffic operations and did not identify any impacts. The site will be directly accessed from West Catlett Road through an existing entrance through a 22-foot-wide access gate. No impacts have been identified by the Development Services Engineering Division or Fire Services indicating an increased hazard will result.

The Engineering Division has required the applicant to construct improvements to allow for controlled access to the site through the existing driveway, which will be included as a condition of approval. The driveway connection to West Catlett Road is required to be paved within the County right-of-way and will require the applicant to obtain an encroachment permit from the County for the driveway improvements. This project will be required to comply with all County roadway safety, emergency access, and design standards. A less than significant impact is anticipated.

(County of Sutter, General Plan Technical Background Report. 2008)

(County of Sutter, General Plan 2030. 2011)

(Wood Rodgers, Traffic Impact Study. 2025)

Potentially Significant Impact	Less Than Significant with Mitigation Incorporated	Less Than Significant Impact	No Impact
--------------------------------	--	------------------------------	-----------

**VIII. TRIBAL CULTURAL RESOURCES.**

a) Would the project cause a substantial adverse change in the significance of a tribal cultural resource, defined in Public Resources Code § 21074 as either a site, feature, place, cultural landscape that is geographically defined in terms of the size and scope of the landscape, sacred place, or object with cultural value to a California Native American tribe, and that is:

i) Listed or eligible for listing in the California Register of Historical Resources, or in a local register of historical resources as defined in Public Resources Code section 5020.1(k), or

<input type="checkbox"/>	<input type="checkbox"/>	<input checked="" type="checkbox"/>	<input type="checkbox"/>
--------------------------	--------------------------	-------------------------------------	--------------------------

ii) A resource determined by the lead agency, in its discretion and supported by substantial evidence, to be significant pursuant to criteria set forth in subdivision (c) of Public Resources Code § 5024.1. In applying the criteria set forth in subdivision (c) of Public Resource Code § 5024.1, the lead agency shall consider the significance of the resource to a California Native

<input type="checkbox"/>	<input type="checkbox"/>	<input checked="" type="checkbox"/>	<input type="checkbox"/>
--------------------------	--------------------------	-------------------------------------	--------------------------

American tribe.

Potentially Significant Impact	Less Than Significant with Mitigation Incorporated	Less Than Significant Impact	No Impact
--------------------------------	--	------------------------------	-----------

**Responses:**

i-ii) **Less than significant impact.** In September of 2014, the California Legislature passed Assembly Bill (AB) 52, which added provisions to the Public Resources Code regarding the evaluation of impacts on tribal cultural resources under CEQA, and consultation requirements with California Native American tribes. The County initiated AB 52 consultation through distribution of letters to the seven (7) Native American tribes provided by the Native American Heritage Commission (NAHC), which include the Mechoopda Indian Tribe of Chico, Mooretown Rancheria of Maidu Indians, United Auburn Indian Community of the Auburn Rancheria, Strawberry Valley Rancheria, Enterprise Rancheria of Maidu Indians, Lone Band of Miwok Indians, and Wilton Rancheria. The Mooretown Rancheria responded and stated that they are not aware of any known cultural resources at this site. No requests for consultation were received from Native American tribes during the review period. The property has been extensively disturbed to varying depths due to previous historical agricultural use and operations on the site. Special events are to be located on an approximate one-acre unused horse-riding arena. A less than significant impact to tribal cultural resources as a result of the project is anticipated.

**XIX. UTILITIES AND SERVICE SYSTEMS.**

Would the project:

Potentially Significant Impact	Less Than Significant with Mitigation Incorporated	Less Than Significant Impact	No Impact
--------------------------------	--	------------------------------	-----------

- |  |                          |                          |                                     |                                     |
|--|--------------------------|--------------------------|-------------------------------------|-------------------------------------|
| a) Require or result in the relocation or construction of new or expanded water, wastewater treatment or storm water drainage, electric power, natural gas, or telecommunications facilities, the construction or relocation of which could cause significant environmental effects? | <input type="checkbox"/> | <input type="checkbox"/> | <input type="checkbox"/>            | <input checked="" type="checkbox"/> |
| b) Have sufficient water supplies available to serve the project and reasonably foreseeable future development during normal, dry and multiple dry years?  | <input type="checkbox"/> | <input type="checkbox"/> | <input checked="" type="checkbox"/> | <input type="checkbox"/>            |
| c) Result in a determination by the wastewater treatment provider, which serves or may serve the project that it has adequate capacity to serve the project's projected demand in addition to the provider's existing commitments?   | <input type="checkbox"/> | <input type="checkbox"/> | <input type="checkbox"/>            | <input checked="" type="checkbox"/> |
| d) Generate solid waste in excess of state or local standards, or in excess of the capacity of local infrastructure, or otherwise impair the attainment of solid waste reduction goals?  | <input type="checkbox"/> | <input type="checkbox"/> | <input checked="" type="checkbox"/> | <input type="checkbox"/>            |
| e) Comply with federal, state, and local management and reduction statutes and regulations related to solid waste?   | <input type="checkbox"/> | <input type="checkbox"/> | <input checked="" type="checkbox"/> | <input type="checkbox"/>            |

**Responses:**

a) **No impact.** This project will not require or result in the relocation or construction of new or expanded water, wastewater treatment, or storm water drainage, electric power, natural gas, or telecommunications facilities, the construction or relocation of which could cause significant environmental effects. This project will require no new water service or wastewater treatment. Food is to be catered and bottled water will be served during events. Two portable restroom trailers will be provided by the event organizers with each trailer having two toilets and one hand washing station. Restrooms will be self-contained and will be required to be serviced by a Sutter County registered septic pumper. The subject property currently drains to the northeast. A small drainage ditch is located on the east side of the property along Vernon Road. This project was reviewed by the Pacific Gas and Electric Company (PG&E) and they stated that there will be no impact; therefore, no impacts are anticipated.

b) **Less than significant impact.** This project will have sufficient water supplies available to serve the project and reasonably foreseeable future development. The project site has historically been used for agricultural purposes and includes wells for irrigation. This project will not utilize onsite water supplies. Bottled water and self-contained portable restrooms with handwashing stations will be provided during events. A tanker will be utilized for sprinkling water on the site prior to events for dust control. As a result, a less than significant impact is anticipated.

c) **No impact.** This project will not result in a determination by a wastewater treatment provider which serves or may serve the project that it has adequate capacity to serve the project's projected demand in addition to the provider's existing commitments. This project is not located in an area that is served by a wastewater treatment provider. Individual on-site sewage disposal systems are currently the only method of providing sewage disposal for the project area. Therefore, a demand will not be placed on a local sanitary sewer system and no impact is anticipated.

d-e) **Less than significant impact.** This project will have a less than significant impact on solid waste. Solid waste is anticipated as a result of project implementation; however, this project does not include any components that will generate excessive waste. A minimum of five trash receptacles will be put in place during events with trash to be hauled to the landfill by volunteers. Solid waste from this project will be disposed of through the local waste disposal company in a sanitary landfill in Yuba County which has sufficient capacity to serve this project. Project disposal of solid waste into that facility will comply with all federal, state, and local statutes and regulations related to solid waste, including recycling. As a result, a less than significant impact is anticipated.

(County of Sutter, General Plan Technical Background Report. 2008)

Potentially Significant Impact	Less Than Significant with Mitigation Incorporated	Less Than Significant Impact	No Impact
--------------------------------------	---	------------------------------------	--------------

**XX. WILDFIRE.**

If located in or near state responsibility areas or lands classified as very high fire hazard severity zones, would the project:

a) Substantially impair an adopted emergency response

	Potentially Significant Impact	Less Than Significant with Mitigation Incorporated	Less Than Significant Impact	No Impact
plan or emergency evacuation plan?				
b) Due to slope, prevailing winds, and other factors, exacerbate wildfire risks, and thereby expose project occupants to pollutant concentrations from a wildfire or the uncontrolled spread of a wildfire?	<input type="checkbox"/>	<input type="checkbox"/>	<input type="checkbox"/>	<input checked="" type="checkbox"/>
c) Require the installation or maintenance of associated infrastructure (such as roads, fuel breaks, emergency water sources, power lines or other utilities) that may exacerbate fire risk or that may result in temporary or ongoing impacts to the environment?	<input type="checkbox"/>	<input type="checkbox"/>	<input type="checkbox"/>	<input checked="" type="checkbox"/>
d) Expose people or structures to significant risks, including downslope or downstream flooding or landslides, as a result of runoff, post-fire slope instability, or drainage changes?	<input type="checkbox"/>	<input type="checkbox"/>	<input type="checkbox"/>	<input checked="" type="checkbox"/>

**Responses:**

a-d) **No impact.** The subject property is not located in or near state responsibility areas or lands classified as very high fire hazard severity zones; therefore, no impacts are anticipated with respect to wildfire hazard.

	Potentially Significant Impact	Less Than Significant with Mitigation Incorporated	Less Than Significant Impact	No Impact
<b>XXI. MANDATORY FINDINGS OF SIGNIFICANCE.</b>				
a) Does the project have the potential to substantially degrade the quality of the environment, substantially reduce the habitat of a fish or wildlife species, cause a fish or wildlife population to drop below self-sustaining levels, threaten to eliminate a plant or animal community, substantially reduce the number or restrict the range of a rare or endangered plant or animal or eliminate important examples of the major periods of California history or prehistory?	<input type="checkbox"/>	<input type="checkbox"/>	<input checked="" type="checkbox"/>	<input type="checkbox"/>
b) Does the project have impacts that are individually limited, but cumulatively considerable? (“Cumulatively considerable” means that the incremental effects of a project are considerable when viewed in connection with the effects of past projects, the effects of other current projects, and the effects of probable future projects)?	<input type="checkbox"/>	<input type="checkbox"/>	<input checked="" type="checkbox"/>	<input type="checkbox"/>
c) Does the project have environmental effects which will cause substantial adverse effects on human beings, either directly or indirectly?	<input type="checkbox"/>	<input type="checkbox"/>	<input checked="" type="checkbox"/>	<input type="checkbox"/>

**Responses:**

a) **Less than significant impact.** No environmental effects were identified in the initial study which indicate this project will have the ability to degrade the quality of the environment, substantially reduce the habitat of a fish or wildlife species, cause a fish or wildlife population to drop below self-sustaining levels, threaten to eliminate a plant or animal community, reduce the number or restrict the range of a rare or endangered plant or animal or eliminate important examples of the major periods of California history or prehistory.

b) **Less than significant impact.** No environmental effects were identified in the initial study which indicates the project will have impacts that are individually limited, but cumulatively considerable.

c) **Less than significant impact.** No environmental effects which will cause substantial adverse effects on human beings either directly or indirectly were identified in the initial study.

### **Bibliography**

- California Department of Conservation. 2020. *Farmland Mapping and Monitoring Program*
- California Department of Conservation, Division of Mines and Geology. 1988. *Special Report 132: Mineral Land Classification: Portland Cement Concrete-Grade Aggregate in the Yuba City-Marysville Production-Consumption Region*
- California Department of Fish and Wildlife. *California Natural Diversity Database*
- California Department of Toxic Substances Control. 2024. *Hazardous Waste and Substances Site List - Site Cleanup (Cortese List)*
- California Department of Water Resources. 2003. *California's Groundwater – Bulletin 118 (Update 2003)*
- County of Sutter. 2008. *General Plan Technical Background Report*
- County of Sutter. 2011. *General Plan 2030*
- County of Sutter. 2011. *General Plan 2030 Climate Action Plan*
- County of Sutter. 2016. *Greenhouse Gas Pre-Screening Measures for Sutter County*
- County of Sutter. 2024. *Zoning Code*
- Feather River Air Quality Management District (FRAQMD), 2010. *Indirect Source Review Guidelines*
- Federal Emergency Management Agency. 2008. *Flood Insurance Rate Map*
- Sacramento Area Council of Governments. 2013. *Sacramento International Airport Land Use Compatibility Plan*
- Sacramento Valley Air Quality Engineering and Enforcement Professionals (SVAQEEP). 2015. *Northern Sacramento Valley Planning Area 2015 Triennial Air Quality Attainment Plan.*
- Sutter Subbasin Groundwater Management Coordination Committee. 2022. *Sutter Subbasin Groundwater Sustainability Plan*
- U.S. Department of Agriculture, Soil Conservation Service. 1988. *Sutter County Soil Survey*
- U.S. Fish and Wildlife Service. 2024. *National Wetlands Inventory*
- Wood Rogers. 2025. *Traffic Impact Study*

### **Attachments:**

1. Project Plans
2. Aerial Photo Exhibit
3. Traffic Impact Study prepared by Wood Rodgers, February 6, 2025

# ADMINISTRATIVE PERMIT FOR SMALL SPECIAL EVENTS FACILITY @ LANDS OF SHRI GURU NANAK DEV SEWA SOCIETY INTERNATIONAL (SGDSSI) 219 W CATLETT RD NICOLAUS, CA 95659 TOTAL SITE AREA - 60.00 ACRES SPECIAL EVENTS AREA - APPROX. 1.0 ACRE APN: #34-090-019, 022 & 023

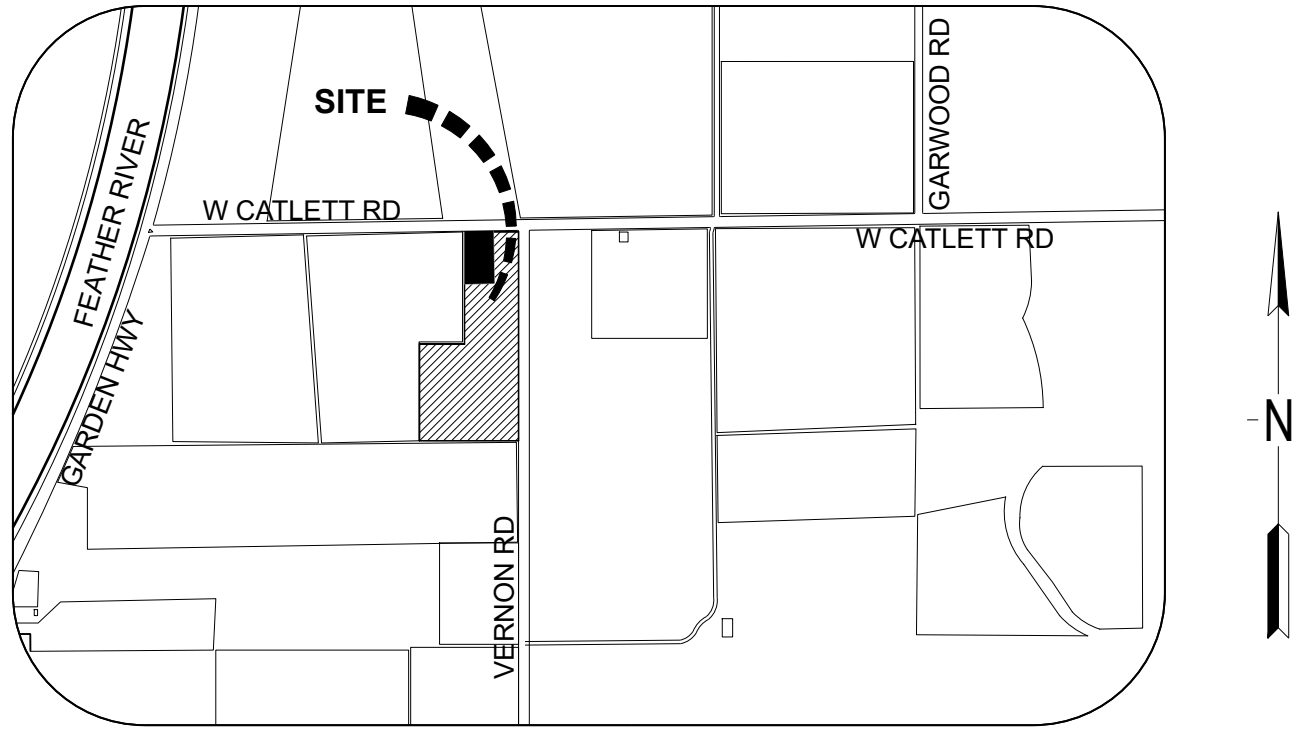

VICINITY MAP

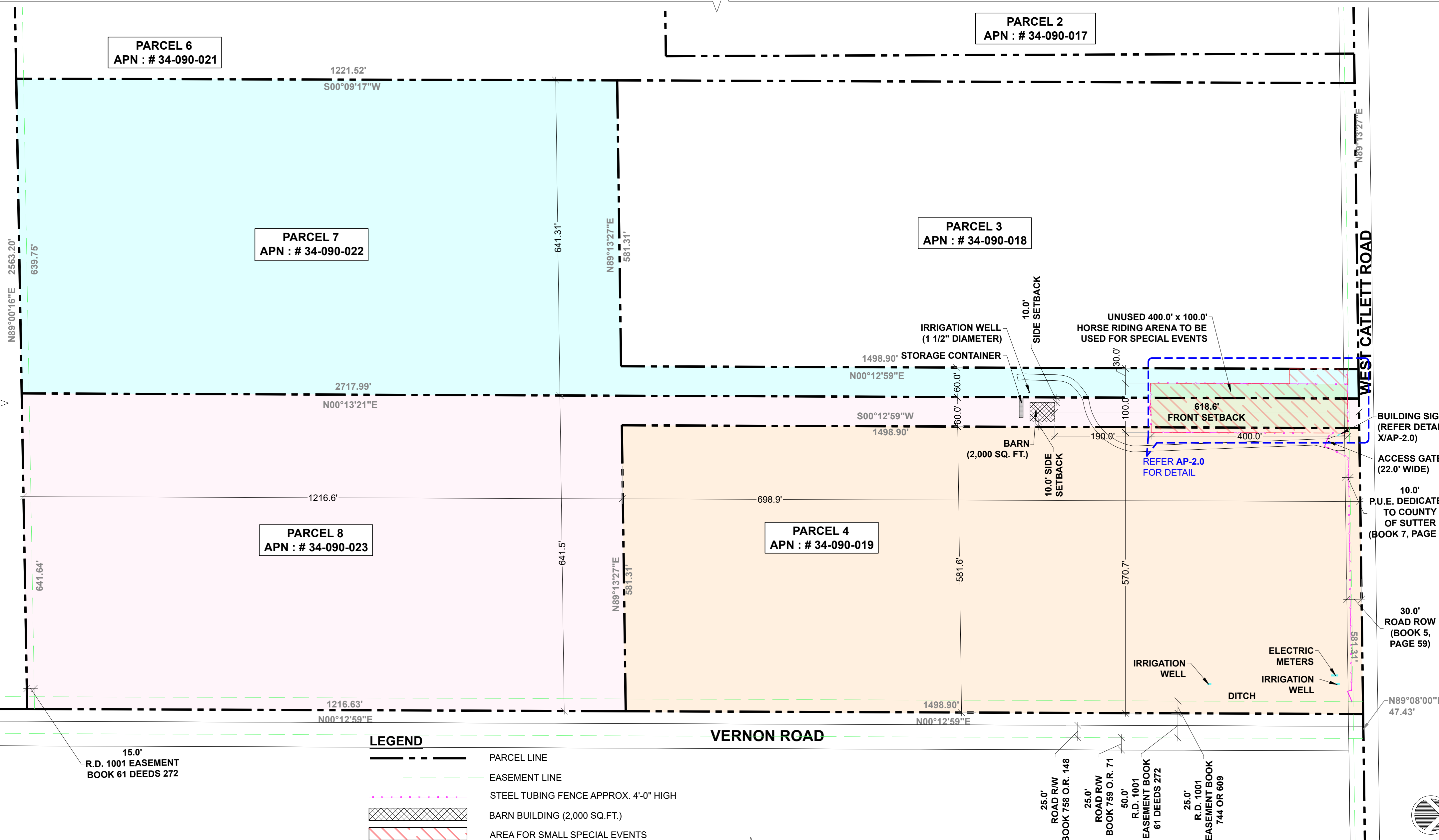

SITE PLAN

SCALE: N.T.S. (FOR REFERENCE ONLY)

**PROJECT DESCRIPTION**

- ADMINISTRATIVE PERMIT FOR SMALL SPECIAL EVENTS FACILITY ACCOMMODATING MAX. 99 GUESTS FOR EACH EVENT. EVENT TO OCCUR BETWEEN SUNRISE & SUNSET WITH MAX. HOURS BETWEEN 7AM - 6PM @ ONE EVENT PER MONTH. EACH EVENT TO HAVE SAME NUMBER OF GUESTS.
- EVENTS TO TAKE PLACE OUTDOORS WITH RENTAL TENTS/CANOPIES AND PORTABLE RESTROOMS MOUNTED ON TRAILERS EQUIPPED WITH HAND WASHING STATIONS PER PLAN.
- FOOD TO BE CATERED AND BOTTLED WATER TO BE SERVED.
- 5 VOLUNTEERS TO WORK AT THE SITE FOR GENERAL UPKEEP AND TO DIRECT TRAFFIC DURING EVENTS. MINIMUM 5 TRASH RECEPTACLES TO BE PLACED DURING EVENT. TRASH TO BE HAULED TO LANDFILL BY VOLUNTEERS.
- APPROXIMATELY 3,500 SQ. FT. TEMPORARY STORAGE AREA PROPOSED FOR EVENT ACCESSORIES, WHEN NOT IN USE, SUCH AS TRASH RECEPTACLES, PORTABLE RESTROOMS AS WELL AS FOR STAGING OF TENTS/CANOPIES MATERIALS HAULED-IN ONE DAY BEFORE EVENT AND TO BE HAULED-OUT ONE DAY AFTER EVENT.
- GROUP PICNICS, BIRTHDAY CELEBRATIONS AND WEDDINGS IN CONTEXT OF RELIGIOUS RITUALS OF SIKH FAITH TO TAKE PLACE. STANDARD SPEAKERS & MIC'S TO BE USED FOR CHANTING & SINGING OF HYMNS FROM SIKH SCRIPTURES, SUCH THAT EVENT SOUND REMAINS WITHIN THE PROPERTY LINES.
- SIGNS TO BE POSTED AT EXISTING BARN STATING "DO NOT ENTER - PRIVATE PROPERTY".

**PROJECT CONTACTS**

APPLICANT	CONSULTANT (DESIGN DEVELOPMENT)
SHRI GURU NANAK DEV SEWA SOCIETY INTERNATIONAL 4934 KOKOMO DRIVE SACRAMENTO, CA 95835	CONTINENTAL DEVELOPMENT CONSULTANTS, INC. P.O. BOX 1924 WOODLAND, CA 95776
<b>CONTACT:-</b> MANJIT SINGH SAINI PHONE: (408) 887-7361 E-MAIL: sewa_society@yahoo.com	<b>CONTACT:-</b> SUKHJIT "TONY" SINGH, PRINCIPAL MANAGER PHONE: (702) 287-0347 E-MAIL: tony@continentaldc.com

**SHEET INDEX**

AP-1.0	COVER SHEET
AP-2.0	ENLARGED SITE PLAN
AP-2.1	ACCESSIBLE PARKING DETAILS
AP-3.0	EXISTING SITE PHOTOS
AP-4.0	EXISTING BARN BUILDING- EXTERIOR ELEVATIONS

**PROJECT DATA**

- PROJECT NAME: SMALL SPECIAL EVENTS FACILITY
- LOCATION: 219 W CATLETT RD, NICOLAUS, CA 95659
- APN #: #34-090-019, 022 & 023
- JURISDICTION: SUTTER COUNTY
- AREA ANALYSIS

APN #	LAND DETAILS	
	TOTAL AREA	SPECIAL EVENTS AREA DETAILS
#34-090-019	20.00 ACRES	0.1 ACRE
# 34-090-022	20.00 ACRES	0.35 ACRE
# 34-090-023	20.00 ACRES	0.55 ACRE
<b>TOTAL AREA</b>	<b>60.00 ACRES</b>	<b>1.0 ACRE</b>

**PLANNING INFORMATION**

- SUTTER COUNTY ZONING CODE
- GENERAL PLAN DESIGNATION: AG-40 (AGRICULTURAL- 40 ACRE MINIMUM)
  - ZONING: AG (AGRICULTURE)

REVISIONS:	REVISION	ISSUE	DATED

**Continental Development Consultants, Inc.**  
Las Vegas, NV  
Woodland, CA  
Phone (702)347-6137; (530)405-3780 • FAX (702)664-6237  
Email: Contact@continentaldc.com  
Civil Engineering • Land Planning and Zoning Entitlements • Building Design and Improvements • Construction Consulting

COVER SHEET  
SMALL SPECIAL EVENTS FACILITY  
219 W. CATLETT RD  
NICOLAUS, CA 95659

TITLE PROJECT



DATE: 09/04/2024  
JOB: GRD-STC-02  
DWG BY: KK  
CHK BY: DV

AP-1.0

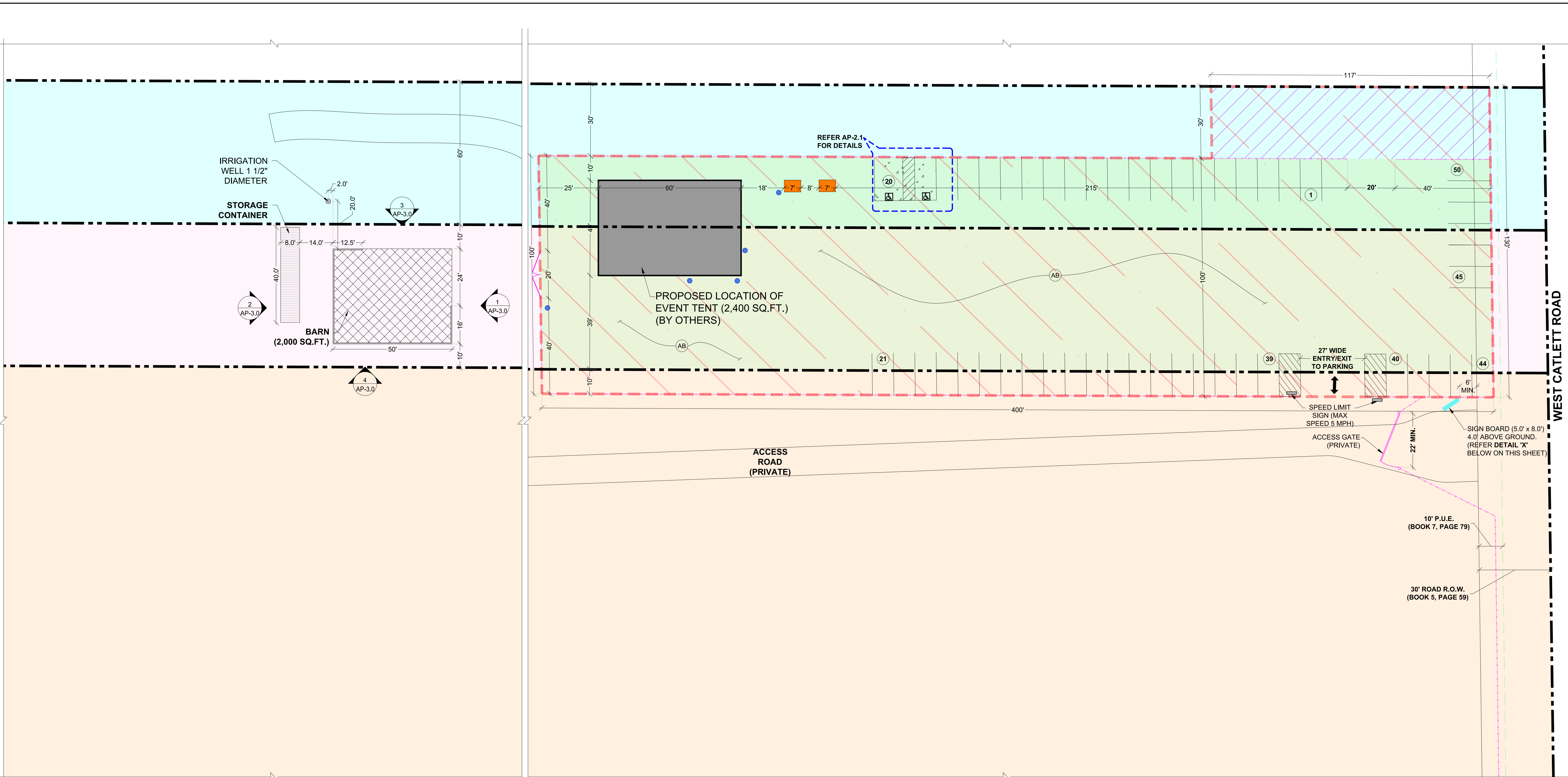

**1 ENLARGED SITE PLAN**  
SCALE: 1:20

- LEGEND:**
- PARCEL LINE
  - BARN BUILDING (2,000 SQ.FT.)
  - AREA FOR SMALL SPECIAL EVENTS (APPROX. 1.0 ACRE)
  - EVENT ACCESSORIES TEMPORARY STORAGE AREA
  - LOOSE GRAVEL @ HORSE RIDING ARENA
  - PROPOSED LOCATION OF EVENT TENT (60.0' x 40.0' APPROX.) (TENT TO BE INSTALLED AND REMOVED BY OTHERS)
  - CONCRETE FINISH ABOVE AGGREGATE BASE @ ACCESSIBLE PARKING
  - NO PARKING
  - PROPOSED LOCATION FOR SEPARATE MEN & WOMEN PORTABLE RESTROOMS (TWO EACH) MOUNTED ON TRAILERS FITTED WITH HAND WASH STATIONS AND HOLDING TANKS FOR WASTE WATER AS SHOWN IN PICTURE 'Y' ON THIS SHEET.

- TRASH RECEPTACLE (MINIMUM - 5)
- SPECIAL EVENT CAR PARKING (9.0' x 18.0') ON LOOSE GRAVEL
- ACCESSIBLE PARKING SPACE
- MINIMUM OF 4 INCHES OF CLASS-2 AGGREGATE BASE GRADED @ 1/2 INCH PER FOOT FROM NORTH TOWARDS SOUTH INSIDE THE EVENT AREA, APPROX 40,000 SQ.FT. (400.0' x 100.0')

**PARKING ANALYSIS**

a) **CAR PARKING (TABLE 1500-20-1)**

• REQUIRED	
- SPECIAL EVENTS FACILITIES (1 PER 2.5 GUEST)	99/2.5 = 39.6 = 40 SPACES
- SPACE FOR VOLUNTEERS	5 SPACES
<b>TOTAL</b>	<b>45 SPACES</b>
• PROVIDED	<b>50 SPACES</b>

b) **ACCESSIBLE PARKING SPACES (SEC. 1500-20-060)**

• REQUIRED	2 SPACES
• PROPOSED	2 SPACES (INCLUDING 1 VAN & 1 STANDARD ACCESSIBLE PARKING)

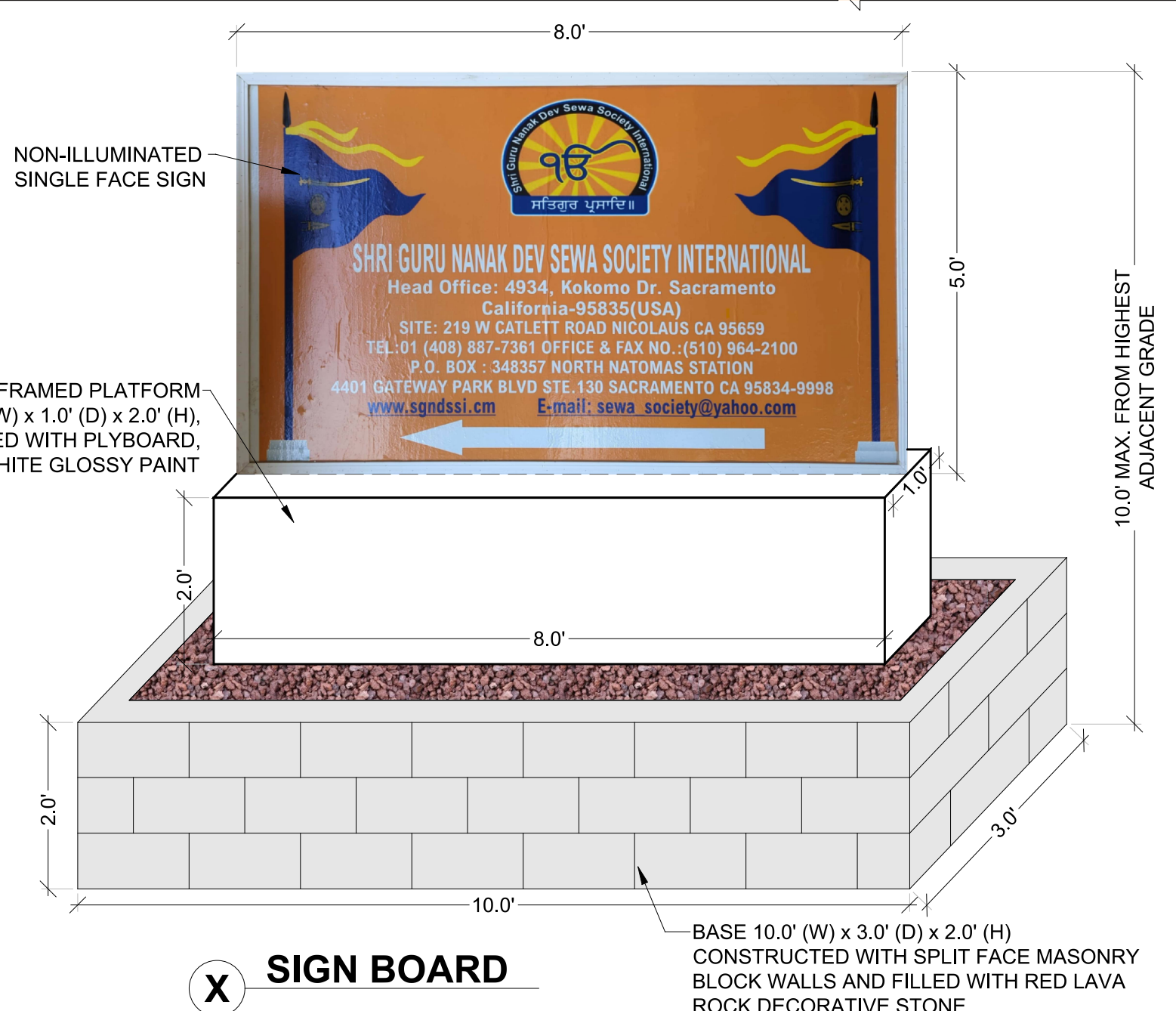

**Y PORTABLE RESTROOM**

REVISIONS:

REVISION	ISSUE	DATE

**Continental Development Consultants, Inc.**  
Woodland, CA  
Las Vegas, NV  
Phone (702)347-6137, (530)405-3780 • FAX (702)664-6237  
Email: Contact@continentaldc.com  
Civil Engineering • Land Planning and Zoning Entitlements • Building Design and Improvements • Construction Consulting

**ENLARGED SITE PLAN**  
**SMALL SPECIAL EVENTS FACILITY**  
**219 W. CATLETT RD**  
**NICOLAUS, CA 95659**

TITLE PROJECT

**AP-2.0**

DATE: 09/04/2024  
JOB: GRD-STC-02  
DWG BY: DV  
CHK BY: SPK

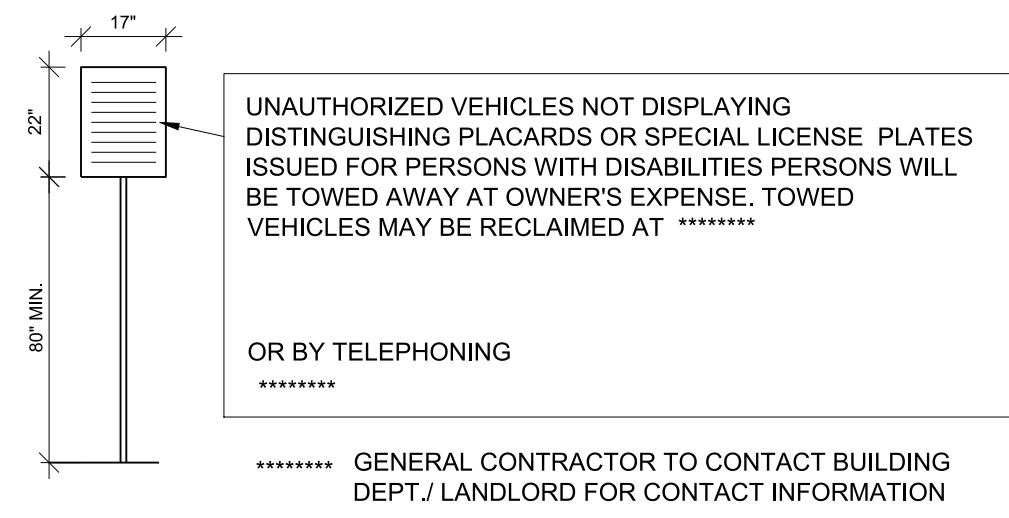

**TOW AWAY SIGN**

SCALE: NTS

6

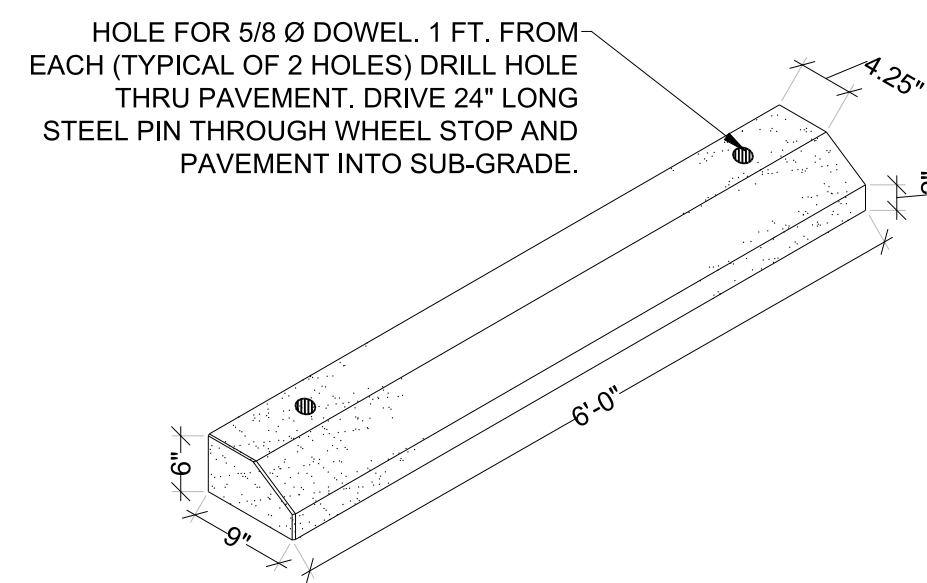

**WHEEL STOP**

SCALE: NTS

4



THE WORDS "NO PARKING", TO BE PAINTED IN WHITE LETTERS NO LESS THAN 1"-0" HIGH ON A CONTRASTING BACKGROUND AND LOCATED SO THAT IT IS VISIBLE TO TRAFFIC ENFORCEMENT OFFICIALS.

**NO PARKING PAVEMENT MARKER**

SCALE: NTS

2

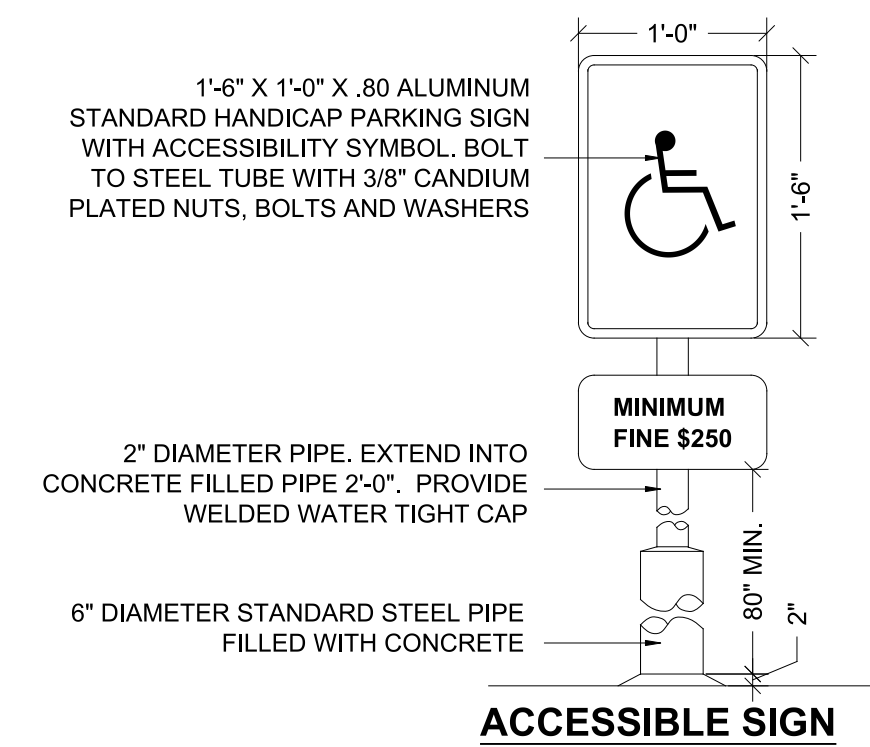

**ACCESSIBLE SIGN**

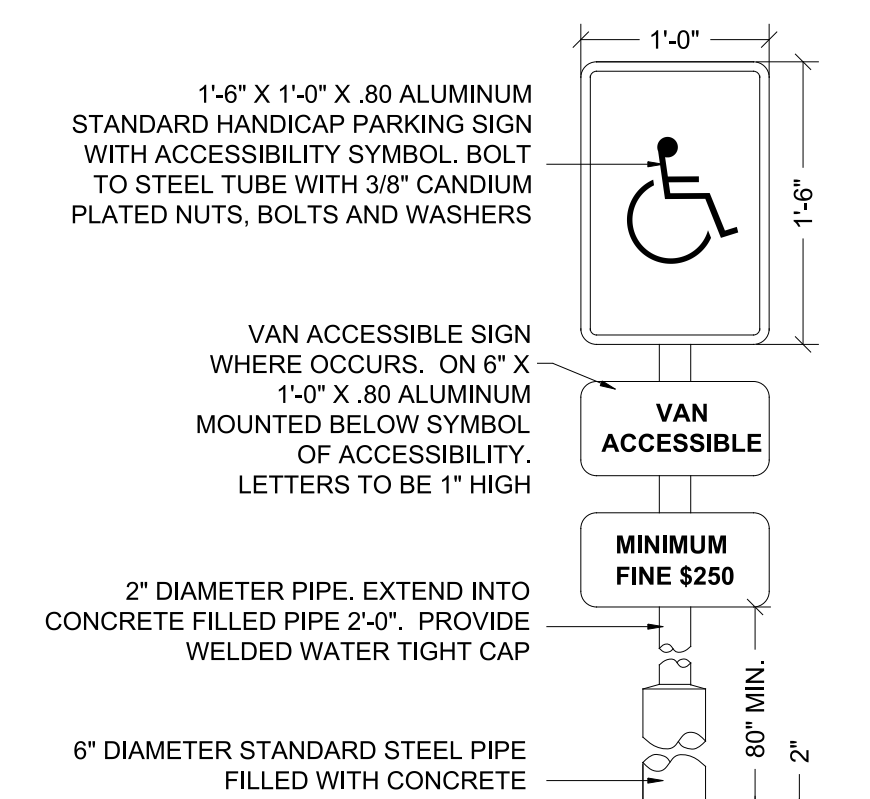

**VAN ACCESSIBLE SIGN**

**DISABLED PARKING SPACE SIGN**

SCALE: NTS

5

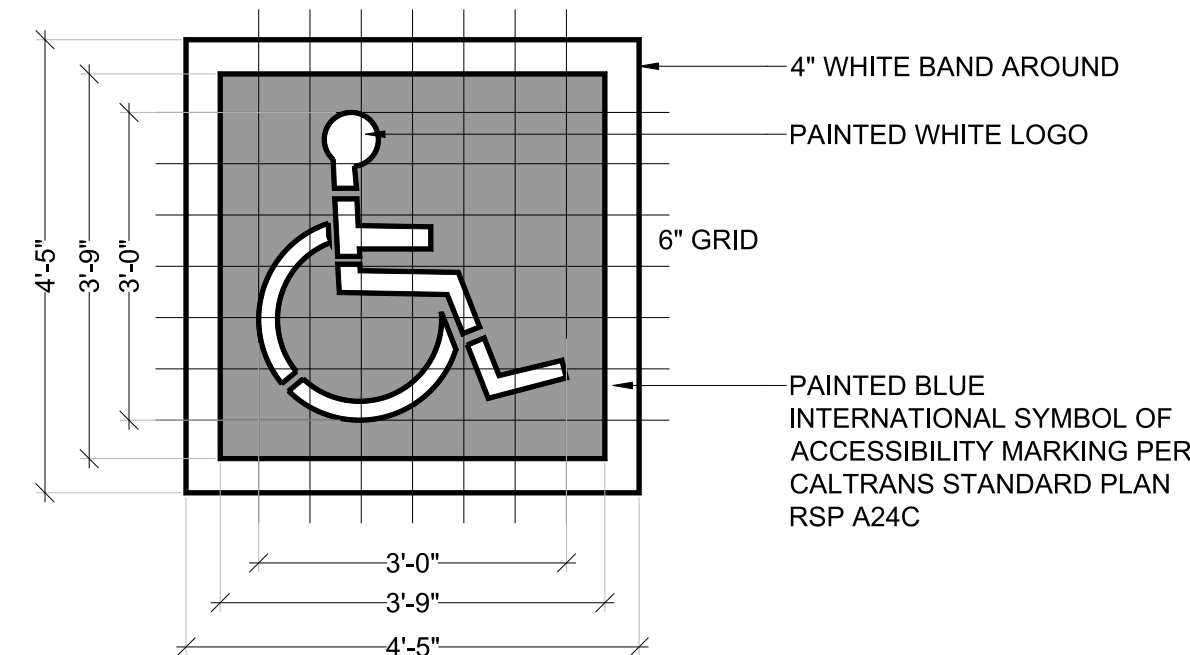

NOTE: SYMBOL TO BE MAX. 6 INCHES FROM THE C OF PARKING SPACE; W/SIDES PARALLEL TO THE LENGTH OF PARKING SPACE AND ITS LOWER CORNER; LOWER SIDE ALLIGNED WITH THE END OF PARKING SPACE.

**ACCESSIBLE PAVEMENT MARKER**

SCALE: N.T.S

3

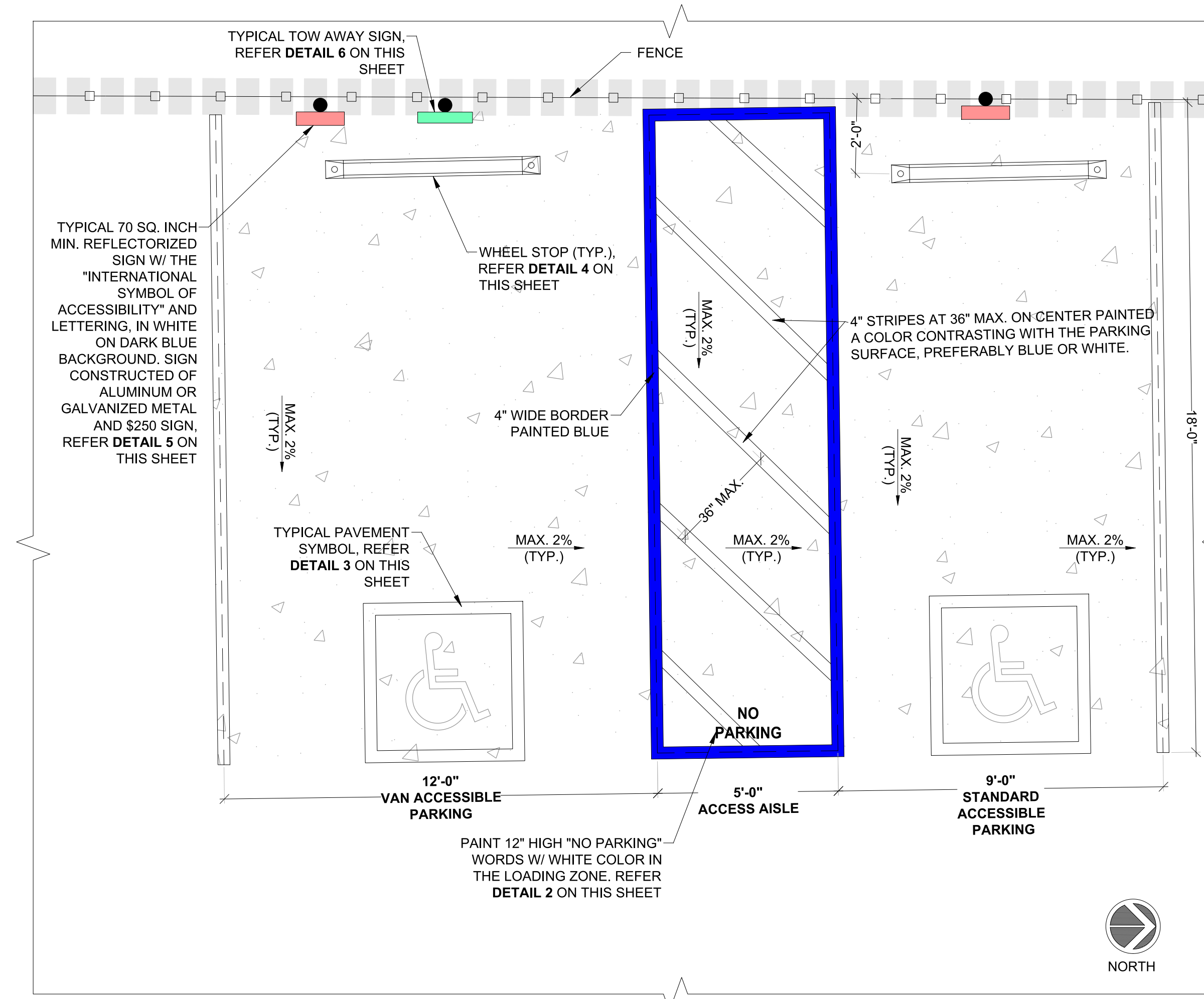

**ACCESSIBLE PARKING DETAIL**

SCALE: 3/8" = 1'-0"

1

REVISIONS:	REVISION	ISSUE	DATED

**Continental Development Consultants, Inc.**  
 Las Vegas, NV  
 Woodland, CA  
 Phone (702)347-6137; (530)405-3780 • FAX (702)664-6237  
 Email: Contact@continentaldc.com  
 Civil Engineering • Land Planning and Zoning Entitlements •  
 Building Design and Improvements • Construction Consulting



**ACCESSIBLE PARKING DETAIL**  
 SMALL SPECIAL EVENTS FACILITY  
 219 W. CATLETT RD  
 NICOLAUS, CA 95659

TITLE  
 PROJECT



DATE: 08/17/2024  
 JOB: GRD-STC-02  
 DWG BY: GK  
 CHK BY: DV

**AP-2.1**



**1 MAIN ENTRANCE - FACING SOUTH FROM W CATLETT ROAD**  
N.T.S.



**2 FACING EAST FROM VERNON ROAD**  
N.T.S.



**3 TOWARDS NORTH WEST**  
N.T.S.



**4 TOWARDS NORTH**  
N.T.S.

REVISIONS:		DATE
REVISION	ISSUE	

**Continental Development Consultants, Inc.**  
Las Vegas, NV  
Woodland, CA  
Phone (702)347-6137; (530)405-3780 • FAX (702)664-6237  
Email: Contact@continentalcd.com  
Civil Engineering • Land Planning and Zoning Entitlements •  
Building Design and Improvements • Construction Consulting



**EXISTING SITE PHOTOS**  
**SMALL SPECIAL EVENTS FACILITY**  
219 W CATLETT RD  
NICOLAUS, CA 95659

TITLE  
PROJECT



DATE: 07/26/2024  
JOB: GRD-STC-02  
DWG BY: KK  
CHK BY: DV

**AP-3.0**



**1 FRONT (NORTH) ELEVATION**  
N.T.S.



**2 REAR (SOUTH) ELEVATION**  
N.T.S.



**4 SIDE (EAST) ELEVATION**  
N.T.S.



**4 SIDE (WEST) ELEVATION**  
N.T.S.

**LEGEND:**

**1** MIN. 11" x 17" SIGN WITH 2 INCH HIGH LETTERS.

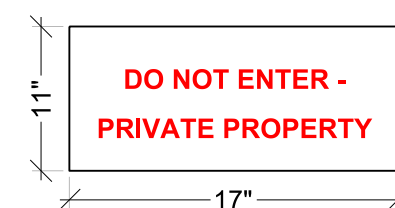

REVISIONS:	REVISION	ISSUE	DATED

**Continental Development Consultants, Inc.**  
Las Vegas, NV  
Woodland, CA  
Phone (702)347-6137; (530)405-3780 • FAX (702)664-6237  
Email: Contact@continentaldc.com  
Civil Engineering • Land Planning and Zoning Entitlements •  
Building Design and Improvements • Construction Consulting



**TITLE** EXISTING BARN BUILDING - EXTERIOR ELEVATIONS  
**PROJECT** SMALL SPECIAL EVENTS FACILITY  
219 W CATLETT RD  
NICOLAUS, CA 95659



DATE: 07/31/2024  
JOB: GRD-STC-02  
DWG BY: KK  
CHK BY: DV

**AP-4.0**



## Legend

- Addresses
- + Railroads
- ▤ Levees
- Open Waterways
  - Irrigation Canal
  - Creek
  - Drainage Ditch
  - River
  - State Drain
  - Ditch (reclass)
  - Natural Waterway (reclass)
  - <all other values>
- Tax Parcels
- ▣ Incorporated Cities
- Road Centerlines
  - 1
  - 3
  - 4
  - 5
  - <all other values>
- ▭ County Boundary 2022 (.25')
  - Red: Band\_1
  - Green: Band\_2
  - Blue: Band\_3

1: 13,387



2,231.2      0      1,115.58      2,231.2 Feet





# Memorandum

**WOOD RODGERS**  
BUILDING RELATIONSHIPS ONE PROJECT AT A TIME

**To:** Casey Murray, Senior Planner  
Sutter County Development Services Department

**From:** Mario Tambellini, PE, TE  
Nicole Scappaticci, PE

**Date:** February 6, 2025

**Subject:** Small Special Events Facility Traffic Impact Study (Project #U24-0021)



## INTRODUCTION

This memorandum has been prepared to present the results of a Traffic Impact Study (TIS) for the proposed Small Special Events Facility (Project) located in Sutter County (County). The purpose of this TIS is to evaluate the Project's transportation impact in the context of the California Environmental Quality Act (CEQA), and consistent with City comments contained in the Sutter County Development Services Department letter for Project #U24-0021 dated October 21, 2024. This TIS includes the following sections:

- Project Description
- Project Trip Generation
- Project Trip Distribution
- Traffic Operations
- Vehicle Miles Traveled Screening Analysis
- Conclusion

## PROJECT DESCRIPTION

The Project is located at 219 West Catlett Road in Sutter County on a site totaling 60-acres. The proposed Special Events Area would lie on a portion of three (3) parcels identified as Assessor Parcel Numbers (APNs) 34-090-19, 022, and 023, totaling approximately 1 acre. Existing zoning of the site is Agriculture (AG), and the General Plan designation of the site is Agriculture – 40 Acre Minimum (AG-40). The site currently includes a barn and agricultural uses that would remain with development of the Project.

The Project proposes to obtain an administrative permit for a small special events facility accommodating a maximum of 99 guests for each event. Events would occur between 7 AM and 6 PM at a frequency of one event per month. Events would take place outdoors with rental tents/canopies, portable restrooms, a 3,500 square foot temporary storage area, and five (5) volunteer workers. Event types would include group picnics, birthday celebrations, and weddings in the context of religious rituals of Sikh faith. The Project would gain access to the surrounding roadway network via an existing driveway on West Catlett Road.

The Project site plan is included in **Figure 1** and the Project location map is shown in **Figure 2**.

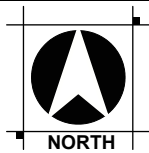
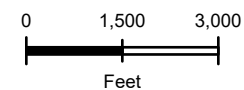



**FIGURE 2**  
**PROJECT LOCATION AND VICINITY MAP**  
 SMALL SPECIAL EVENTS FACILITY TIS  
 SUTTER COUNTY, CA  
 FEBRUARY 2025

Legend

Project Site



## PROJECT TRIP GENERATION

Trip generation for the Project site has been estimated based on information provided by the applicant. The site would host one event per month with up to 99 guests and five (5) volunteers for general upkeep and to direct traffic during events, for a potential total of up to 104 site visitors per event. County parking guidelines require 1 space per 2.5 guests, and 1 space for each volunteer. The Project site includes 45 spaces for special event guests and five (5) spaces for volunteers, for a total of 50 parking spaces, which exceeds County requirements.

Based on an assumed vehicle occupancy of 2.5 persons per vehicle for guests and 1.0 persons per vehicle for volunteers, the site could generate up to 45 trips before an event (40 guest trips and 5 volunteer trips) and 45 trips after an event (40 guest trips and 5 volunteer trips), resulting in a daily trip generation of 90 trips. Note that events may take place during weekends or off-peak weekday periods, and volunteers would likely arrive/depart outside of the peak arrival/departure hours of the events to assist with set-up and tear-down.

**Table 1** provides a summary of the estimated Project trip generation.

**Table 1. Project Trip Generation Summary**

Land Use	Project Use Information	Daily <sup>1</sup>	Event Arrival Hour <sup>1</sup>			Event Departure Hour <sup>1</sup>		
			In	Out	Total	In	Out	Total
Small Special Event Facility	Max. 99 guests per event plus 5 volunteers (one event per month)	90	40	0	40	0	40	40

*Notes:*  
<sup>1</sup>Trip rates are calculated based on an assumed vehicle occupancy of 2.5 for guests and 1.0 for volunteers. Assumes volunteers arrive/depart before/after the primary event arrival and departure hours for guests.

## PROJECT TRIP DISTRIBUTION

Project trips would generally access the surrounding regional roadway network via the West Catlett Road intersection with State Route 99 (SR 99). Assuming that 50% of Project trips travel to/from the Sacramento region (SR 99 south of West Catlett Road) and 50% of Project trips travel to/from the Yuba City region (SR 99 north of West Catlett Road), the West Catlett Road intersection with Northbound/Southbound SR 99 would experience up to 40 Project trips during the event arrival hour and event departure hours. **Table 2** summarizes the estimated Project trips added to the intersection.

**Table 2. Project Trip Assignment**

SR 99 & West Catlett Road			
Time Period	Project Trips Added <sup>1</sup>	Movement <sup>1</sup>	Total
Event Arrival Hour	20	NBL	40
	20	SBR	
Event Departure Hour	20	EBR	40
	20	EBL	

*Notes:*  
<sup>1</sup>Assumes 50% of Project trips travel to/from the Sacramento region (SR 99 south of West Catlett Road) and 50% of Project trips travel to/from the Yuba City region (SR 99 north of West Catlett Road).

## TRAFFIC OPERATIONS

Note that for each time period, half of the estimated Project trips (approximately 20 trips) would be making a free right-turn onto West Catlett Road (southbound right) or Southbound SR 99 (eastbound right-turn), therefore contributing minimal delay to the West Catlett Road & Northbound/Southbound SR 99 intersection. As the Project would generate only up to 40 “event hour” trips, and monthly events are likely to

---

occur outside of peak commute hours, the Project is not anticipated to adversely affect operations of West Catlett Road or the SR 99 & West Catlett Road intersection. The Project is projected to be consistent with Sutter County General Plan policies, including Policy M2.5 (Level of Service on County Roads).

## **VEHICLE MILES TRAVELED SCREENING ANALYSIS (CEQA)**

Senate Bill 743 (SB 743), signed in 2013, required changes to CEQA guidelines on the measurement and identification of transportation impacts due to new projects in California. Revised CEQA Guidelines were adopted in 2018 which identified vehicle miles traveled (VMT) as the most appropriate metric to evaluate transportation impacts. Statewide implementation of assessment of VMT as a metric of transportation impact occurred for all jurisdictions on July 1, 2020. The Governor's Office of Planning and Research (OPR) *Technical Advisory on Evaluating Transportation Impacts in CEQA* (OPR Technical Advisory) (December 2018), contains technical recommendations regarding assessment of VMT, thresholds of significance, and mitigation measures. As the County has not currently adopted guidelines for the analysis of VMT due to new developments, VMT analysis for the proposed Project has been performed in accordance with guidance from the OPR Technical Advisory.

The OPR Technical Advisory states that "Absent substantial evidence indicating that a project would generate a potentially significant level of VMT, or inconsistency with a Sustainable Communities Strategy (SCS) or general plan, projects that generate or attract fewer than 110 trips per day generally may be assumed to cause a less-than-significant transportation impact." As Shown in **Table 1**, the Project is estimated to generate fewer than 110 daily trips on event days. Since events would only be held approximately once a month, the annual average daily trips generated by the Project would be only approximately 3 trips per day (90 event day trips x 12 events per year / 365 days per year). Therefore, VMT impact due to the Project is assumed to be **less-than-significant**. As a result, the Project is screened out from further VMT analysis and would not have CEQA impacts, including under cumulative conditions.

## **CONCLUSION**

The proposed Project is anticipated to generate up to 45 trips during arrival and departure periods before and after an event, resulting in a daily trip generation of 90 trips. The Project is estimated to add up to 40 trips to the SR 99 & West Catlett Road intersection during event arrival and departure hours. However, as approximately half of those trips would make free right-turns onto/off of SR 99, and as the monthly events would likely occur outside of peak commute hours, the Project is not anticipated to adversely affect operations of nearby roadway facilities.

Based on OPR guidance, as the Project would generate fewer than 110 daily trips on an annualized average basis, VMT impact due to the Project is assumed to be **less-than-significant**. As a result, the Project is screened out from further VMT analysis and would not have CEQA impacts, including under cumulative conditions.